

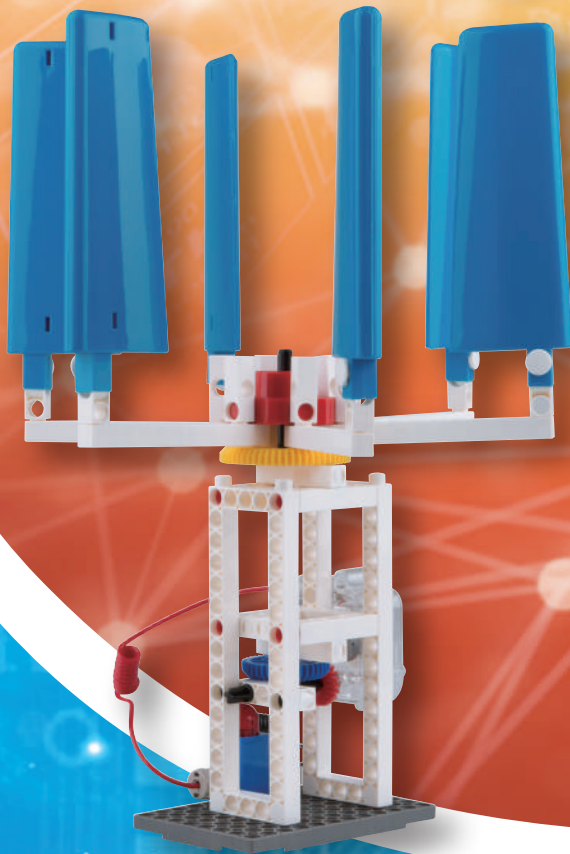

WIND POWER

LEARNING LAB



#1239RR

154 PCS

7+



INVENTING CAN BE LEARNED

20 EXPERIMENTS INCLUDED



INVENTING CAN BE LEARNED

Gigo Learning Lab's complete series includes individual packages and school sets. The special features of Gigo's Learning Lab are as follows:

1. Using Gigo's "building block" construction-based curriculum, every class has a ready-to-assemble model, and includes time designed to promote individual creativity.
2. Promotes thinking outside-the-box of the traditional educational framework by learning innovation through play!
3. We are all innately good at something, so we should take into account both individual development and the ability to work as part of a team effort.
4. Course levels are designed from elementary to difficult, combining a life sciences-based curriculum with applications from daily life.
5. Experiment using Gigo's "building blocks", which can be used over and over again, saving both time and effort.





















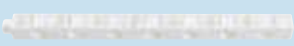













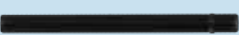





We hope that kids can enthusiastically learn scientific knowledge through fun hands-on experience, developing their problem-solving abilities, as well as a positive attitude towards science. Our mission is to help children apply their newfound knowledge to daily life, furthering their innovational skills and abilities.

Index

Education Philosophy	1	10. Monograph (2)	39
Index	2	11. Long-blade Windmill	41
Parts List	3	12. Variable-speed Windmill	45
1. Hand-held Windmill	5	13. Wind-powered Scarecrow	49
2. Hand Powered Fan	9	14. Windmill Generator	53
3. Wind Vane	13	15. Monograph (3)	57
4. Wind Power Measurer	17	16. Micro Wind Turbine	59
5. Monograph (1)	21	17. Wind Sensing Generator	63
6. Sail Car	23	18. Vertical Wind Powered Generator	67
7. Fan Blade Tester	27	19. Electric Fan	71
8. Wind-powered Whisk	31	20. Monograph (4)	75
9. Strong Wind Warning Indicator	35	Appendix Paper card	77

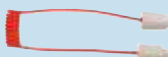

Parts List

								
1	2	3	4	5	6	7	8	
x1	x1	x10	x20	x20	x3	x6	x5	
								
9	10	11		12	13	14		
x8	x6	x2		x4	x4	x4		
								
15	16	17	18	19	20	21	22	
x5	x2	x2	x2	x2	x1	x2	x2	
								
23	24	25		26		27	28	
x2	x2	x2		x2		x1	x4	
								
29	30	31	32	33	34	35	36	
x3	x1	x3	x3	x1	x3	x1	x1	
								
37	38		39	40	41	42		
x3	x6		x1	x1	x1	x1		

Parts List:

No.	Description	Item No.	Qty.	No.	Description	Item No.	Qty.
1	B-PEG REMOVER	7061-W10-B1Y	1	23	C-30mm AXLE II	7413-W10-N1D	2
2	C-BASE GRID	7125-W10-A1SK	1	24	C-70mm AXLE II	7061-W10-Q1D	2
3	C-SHORT BUTTON FIXER	7061-W10-W1W	10	25	C-100mm AXLE II	7413-W10-L2D	2
4	C-LONG PEG	7061-W10-C1R	20	26	C-150mm AXLE I	7026-W10-P1D	2
5	B-SHORT PEG	7344-W10-C2D	20	27	C-ROD CONNECTOR	7026-W10-L2W	1
6	C-3 HOLE ROD	7026-W10-Q2W	3	28	C-TWO-IN-ONE CONVERTER	7061-W10-G1W	4
7	C-3 HOLE DUAL ROD	7413-W10-Y1W	6	29	C-AXLE	7026-W10-H1O	3
8	C-5 HOLE ROD	7413-W10-K2W	5	30	C-CRANK	7063-W10-B3S1	1
9	C-5 HOLE DUAL ROD	7413-W10-X1W	8	31	C-AXLE FIXING	3620-W10-A1D	3
10	C-11 HOLE ROD	7413-W10-P1W	6	32	C-20mm AXLE CONNECTOR	7413-W10-T1B	3
11	C-15 HOLE DUAL ROD	7413-W10-Z1W	2	33	C-2000mm STRING	R39-W85-200	1
12	C-BENDED ROD	7061-W10-V1W	4	34	C-WASHER	R12#3620	3
13	C-5X5 FRAME	7413-W10-Q1W	4	35	C-16X MOTOR	1114-W85-E1K	1
14	C-5X10 FRAME	7413-W10-I1W	4	36	C-LED HOLDER	7050-W85-6RL	1
15	C-5X15 FRAME	7413-W10-J1W	5	37	C-LONG BLADE	7324-W10-A1W	3
16	C-LATERAL CONVERTER	7061-W10-X1W	2	38	C-SHORT BLADE	7324-W10-C1B	6
17	C-20T GEAR	7026-W10-D2R	2	39	C-UNIVERSAL ADAPTER	3680-W85-A2R	1
18	C-40T GEAR	7346-W10-C1B	2	40	C-WIRE CONNECTOR	7050-W85-5R	1
19	C-60T GEAR	7026-W10-W5Y	2	41	C-WIRE CONNECTOR	7050-W85-5D	1
20	C-80T GEAR	7328-W10-G2O	1	42	C-1.5V BATTERY HOLDER WITH FUSE II	7050-W85-O1	1
21	C-OD33mm PULLEY	7344-W10-N2S1	2		C-1.5V BATTERY HOLDER LID III	7455-W10-C1Y	1
22	C-OD53mm PULLEY	7344-W10-N1S1	2				

Keep the instruction since it contains important information.

Requires 1 AA/LR06 battery - not included.

TIPS AND TRICKS:

Here are a few tips for assembling and using the models. Read them carefully before starting.

NG! (without space) OK! (with space)



Fig.1

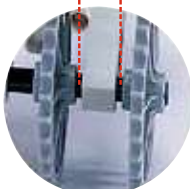

Fig.2

A. Pay attention to the hole:

When fixing gears onto the frame with drive axle be sure to keep a proper space (about 1mm) between the gear and the frames (Fig. 2). And try to turn the gear to ensure every gear in the gear train turning smoothly so that the least friction will be created and most efficient power transmission can be expected.

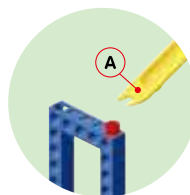

Fig.3

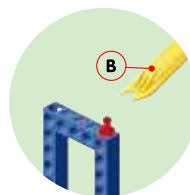

Fig.4

B. B-Peg remover:

Using peg remover to pull peg off as Fig.3 shows.
Using peg remover to pull axle off as fig.4 shows.



For more assembly tips, please refer to

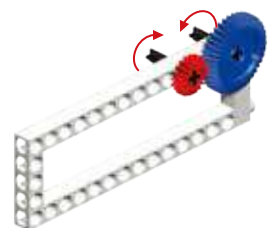

C. Gear wheels:

The models will often have several gear wheels installed in a row, or gear train. In order for the models to work well, these gear wheels will have to mesh well. Otherwise, the force from one gear wheel won't be properly transferred to the next.

How to insert battery:

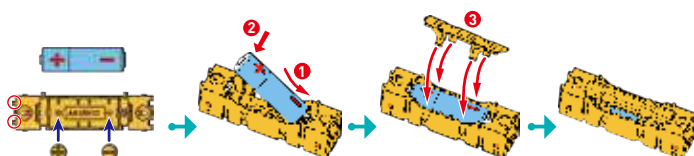

How to remove battery:

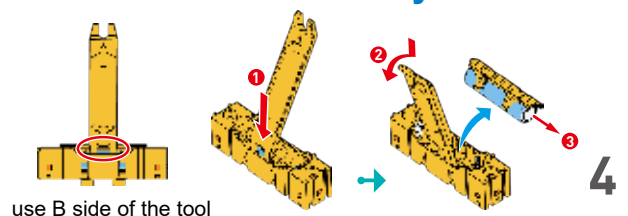

use B side of the tool



One weekend, after Mummy took Gigi on a tour around a park with plastic pinwheels, Gigi was inspired to decorate their home yard with a few windmills. Mummy invited Gigi to make paper windmills so they prepared color paper, thumbtacks, straws, and made colorful toy versions of real windmills. Later, Gigi held a paper windmill she had made in front of an electric fan, to see if it worked, but it didn't turn smoothly.

After a closer inspection, Gigi noticed that the windmill blades were unevenly cut and they were occasionally getting stuck as they turned.

Gigi then made another windmill, and this time she was very careful as she made it. Finally, the windmill blades spun smoothly! Eager to share her success, Gigi rode her bike over to her friend's house with a windmill on the front of the handlebars. As she passed through a space between two buildings, a strong gust of wind blew her and the bike, nearly causing her to fall off! Luckily, she managed to keep her balance and kept moving. She finally reached her friend's house safely.

Daily Application

When walking between two tall buildings, you may feel the wind suddenly become stronger, but once you are out of the vicinity, the winds subside. This is the so-called skyscraper effect. Two tall buildings act like mountain cliffs, forming a canyon-like terrain, and therefore it is also known as the urban canyon effect. Winds blowing through the long, narrow space are forced into a narrow channel, and as a result there is a much higher wind pressure.

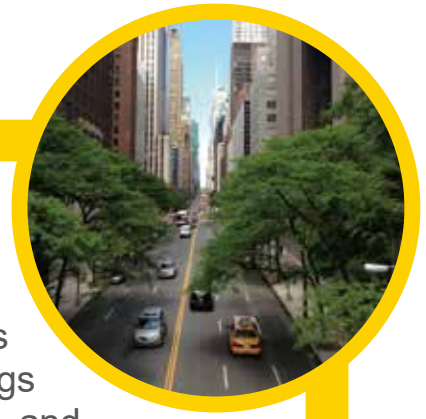

Brainstorming

Have you ever been blown so hard by the wind that you couldn't move forward?

Parts List

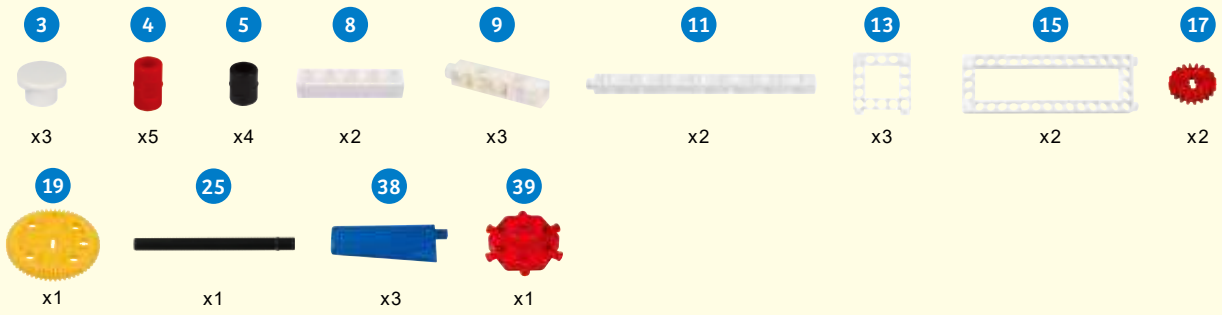

1 x2

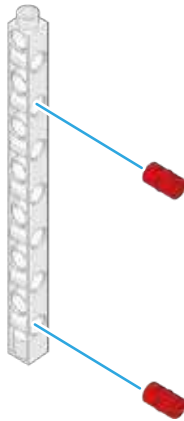

2

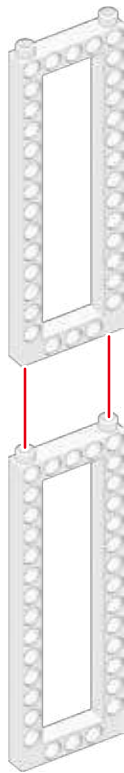

3

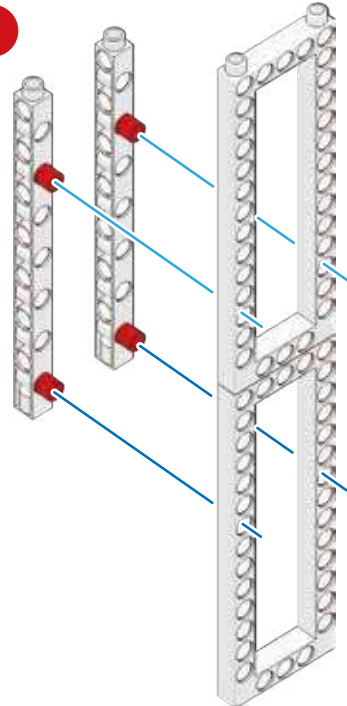

4

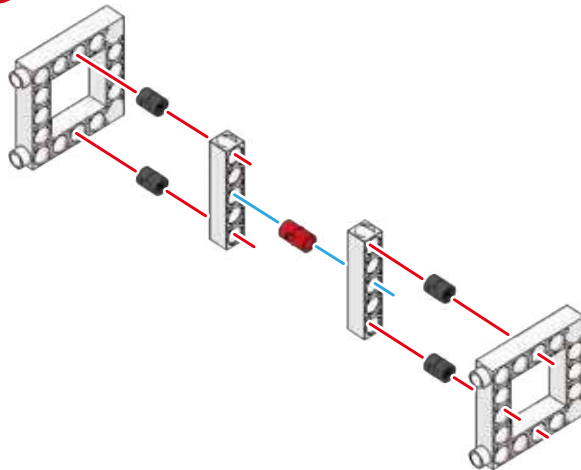

5

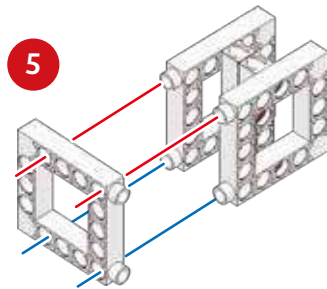

1

Hand-held Windmill

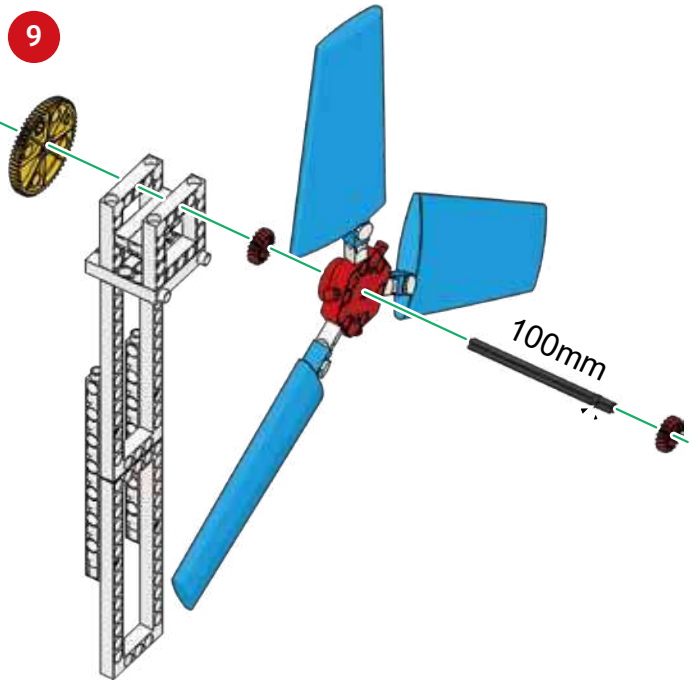
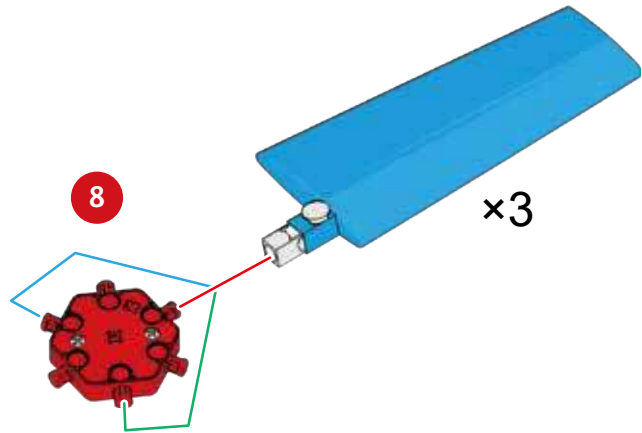
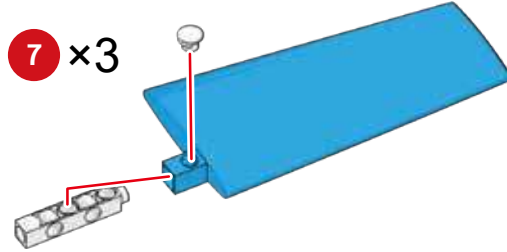
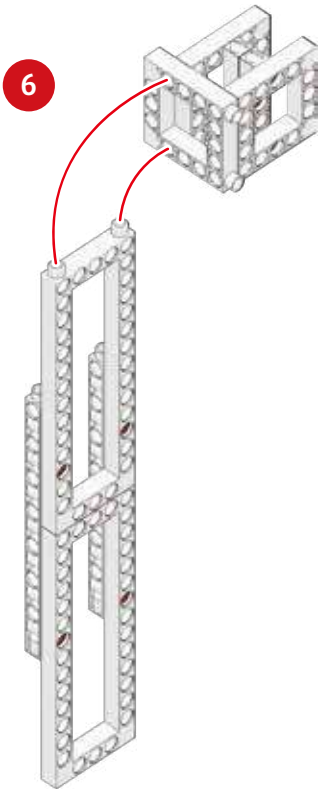

Done



Model Operation
Video



How strong does the wind need to be in order to rotate the Hand-held Windmill?

Blank writing area with horizontal dotted lines for notes.



Use your imagination. How would you change the style of the Hand-held Windmill?

Blank writing area with horizontal dotted lines for notes.

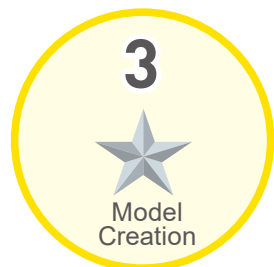
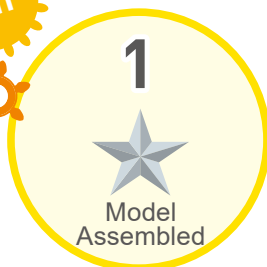



Grandpa took Gogo to the park so he could fly a kite. Grandpa looked up at the trees and saw that there was no wind. He said, “How can we fly a kite on such a windless day!”

Gogo also knew that a kite could not fly without the wind. Out of frustration, both of them just decided to go back home. But then, Gogo saw someone running in the park and had an idea. He held the kite high and tried to create his own breeze by running. He was able to fly the kite and didn't stop running until he reached the end of the park.

Gogo was tired, but deep down he was happy. It was his first time flying a kite and he was proud of himself for solving the wind problem by himself.

Daily Application



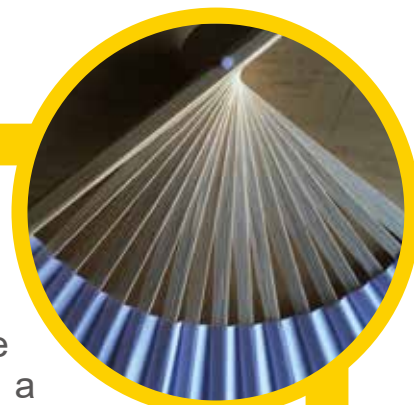







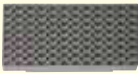

Solar thermal energy and the Earth's rotation cause air to flow in different directions and speeds across the Earth's surface, we call it “the wind”. Wind is the displacement of air in relation to an object. It is a concept of relative motion. Outdoors, the wind blows from a high pressure area to a low pressure area. Airflow is the source of the wind. On a windless day or indoors, we often create artificial wind by utilizing devices that generate air flow. For instance, people use electric fans to cool themselves during the hot summer.

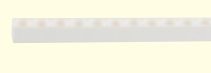

Brainstorming

Besides flying a kite, which activities can be enjoyed on a windy day?

Parts List

2  x1	3  x3	4  x5	7  x3	9  x3	10  x1	14  x2	15  x2
26  x1	30  x1	31  x2	38  x3	39  x1			

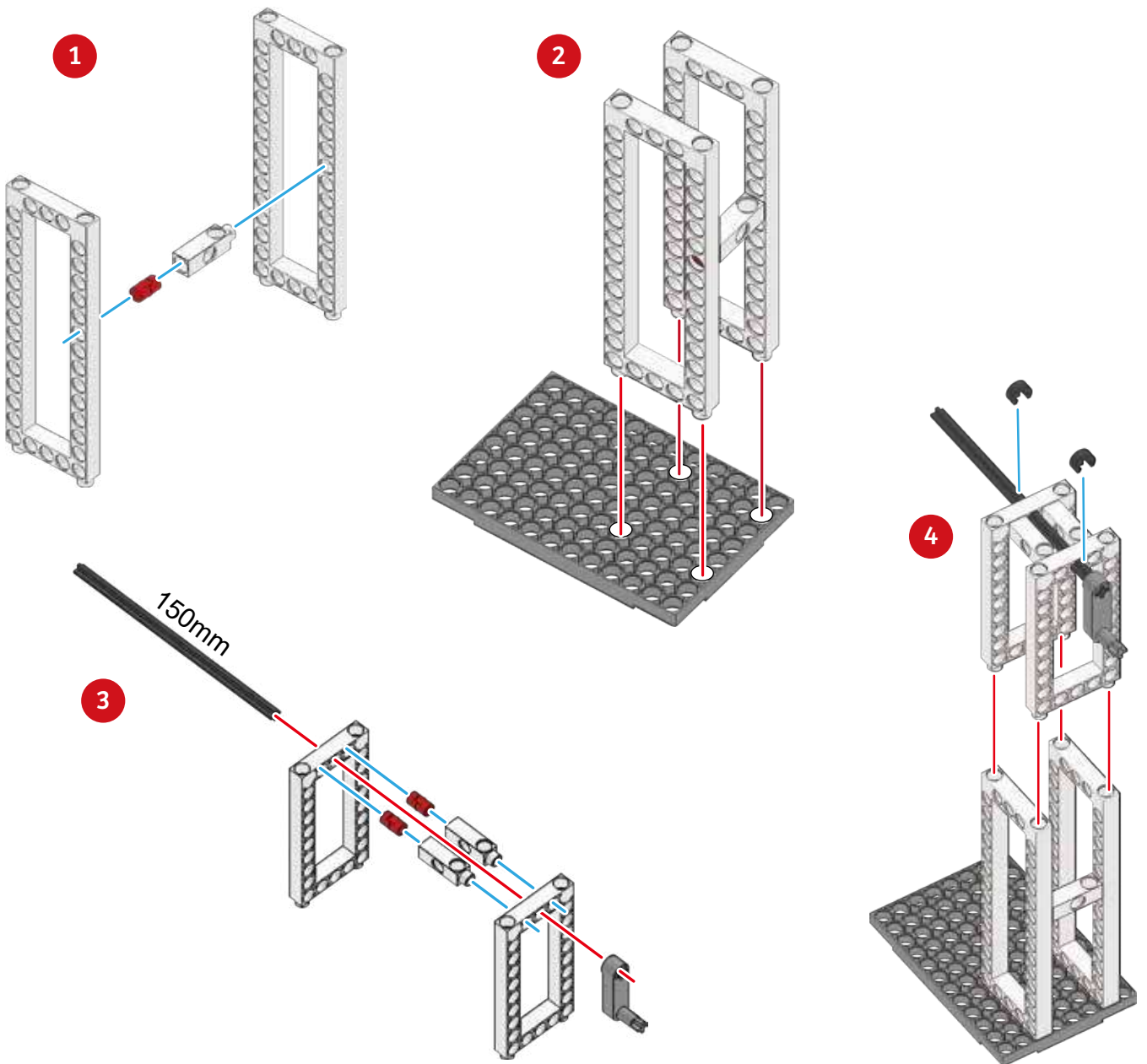

2

Hand Powered Fan

5 x3

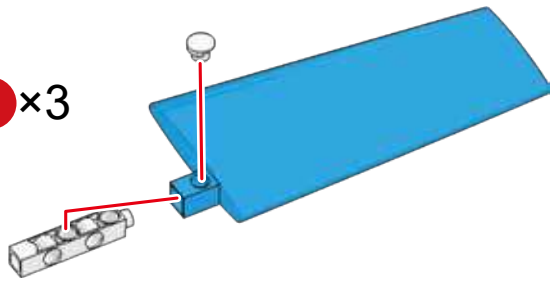

7

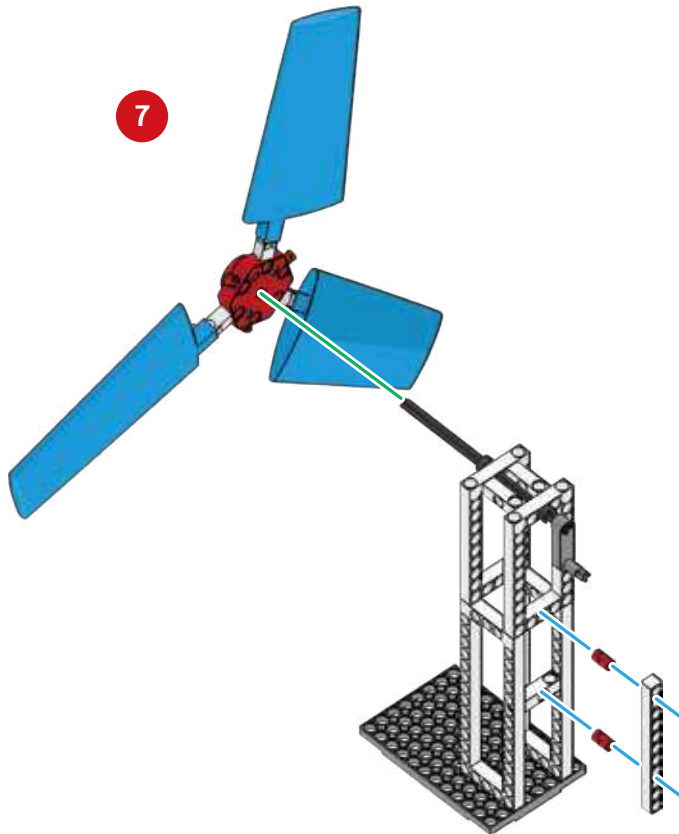

6

x3

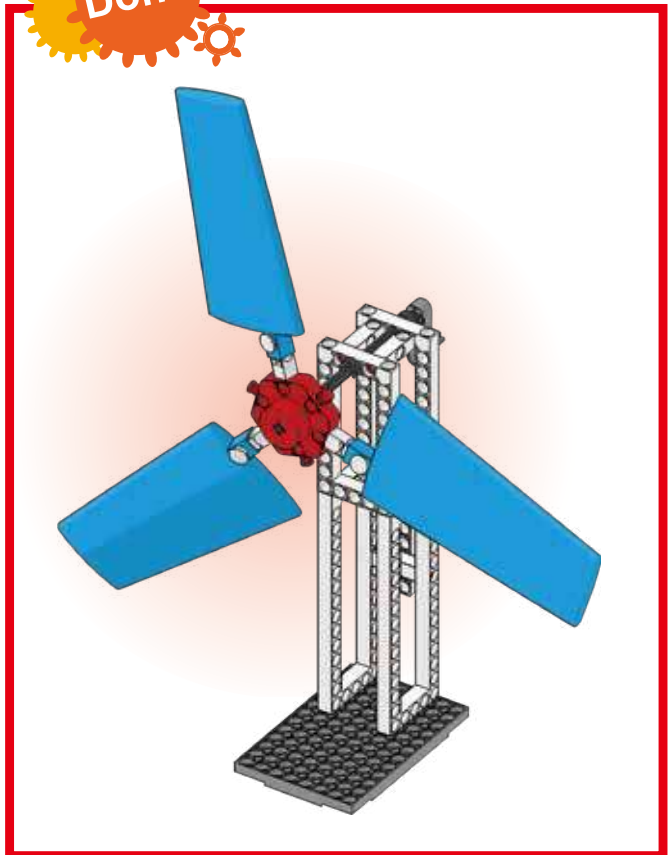
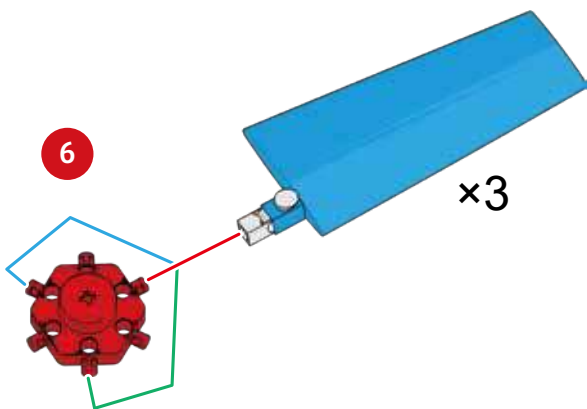

Model Operation Video



Hang a sheet of A4 size paper in front of the model to find the maximum angle of the paper when your model blows on it.

Blank writing area with horizontal dotted lines for notes.

How can you modify the model to increase the power of the hand fan?



Blank writing area with horizontal dotted lines for notes.

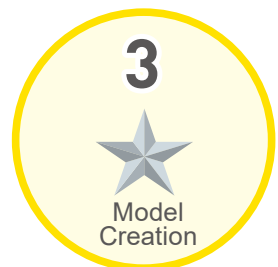
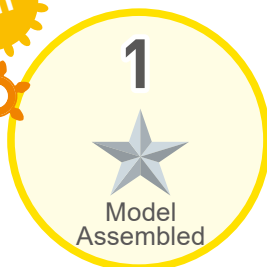



Heat makes air expand and rise. Also, air density decreases when there is a larger volume to fill, but the mass remains unchanged. These two aspects of temperature and volume create a flow of air, hot air rising, and cooler, denser air flowing in underneath. This is what we call wind.

Wind direction refers to the direction from which the wind originates. Wind originating from the north is called the north wind, and that from the south is called the south wind. The simplest way to measure wind direction is to hold a finger up in the air. The side of the finger that gets cold is where the wind is coming from. As humans developed numerous tools for measuring wind direction were invented, such as the windsock and wind vane.

Daily Application

The tail end of the arrow on the wind vane must have a greater surface area that gives resistance to the wind, the pointed end has less resistance.

This makes the arrow-head point in the direction from which the wind is blowing. The center of gravity of the arrow is connected with the vertical axis to form a cross. The wind continues to move the instrument until the indicator is parallel to the wind direction.















The direction of the arrow head indicates the wind direction. If this principle is hard to understand, have a try. Bend over the wind vane and look down on it from above. As it rotates around the center you can see that it is like a see-saw, a wind vane is just another application of the leverage principle.



Brainstorming

What methods can be used to determine wind direction?

Parts List

2  x1	3  x1	4  x3	5  x8	7  x1	8  x5	11  x2	12  x2	13  x1
15  x2	17  x1	18  x1	25  x1	38  x1				

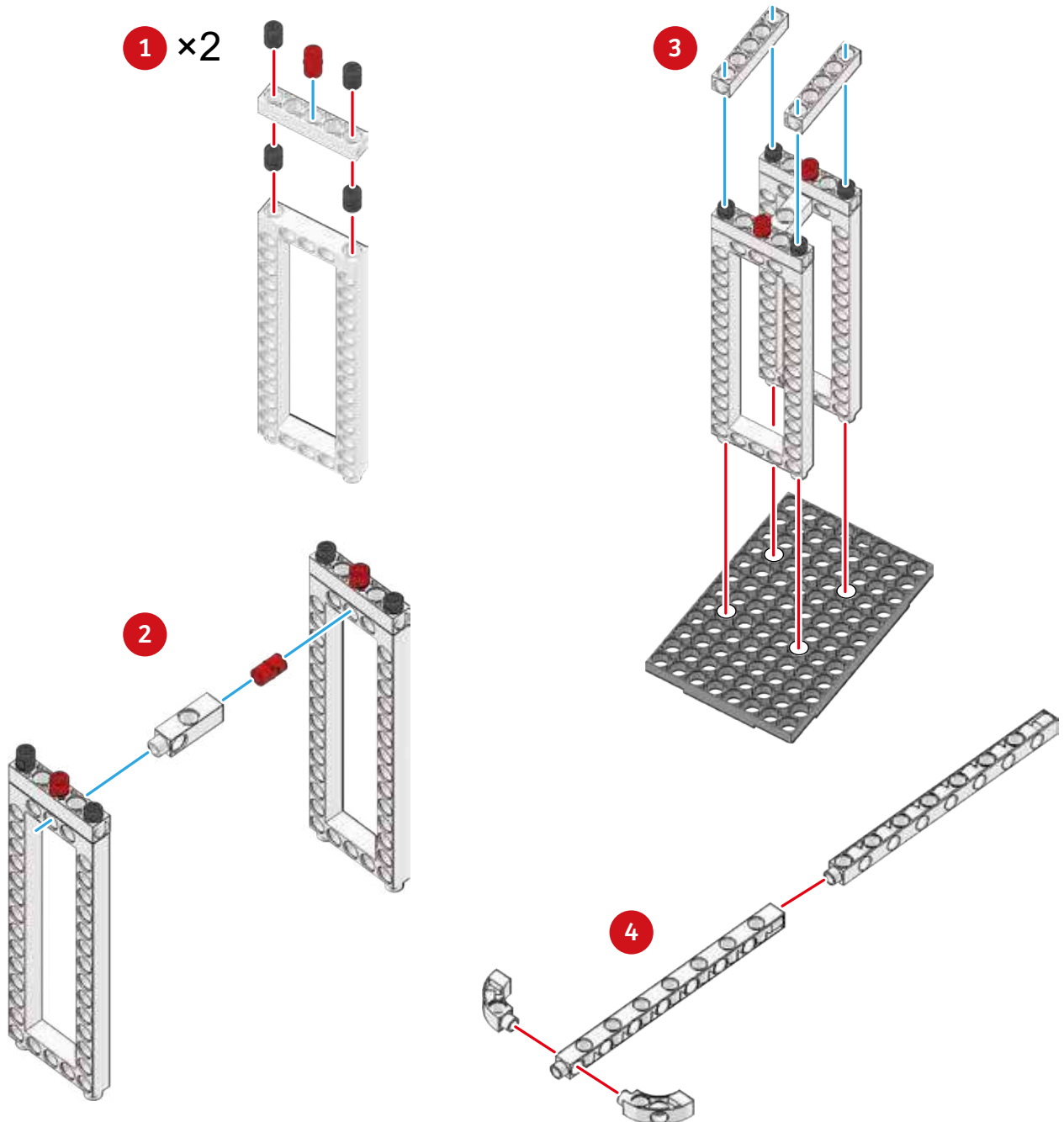

3

Wind Vane

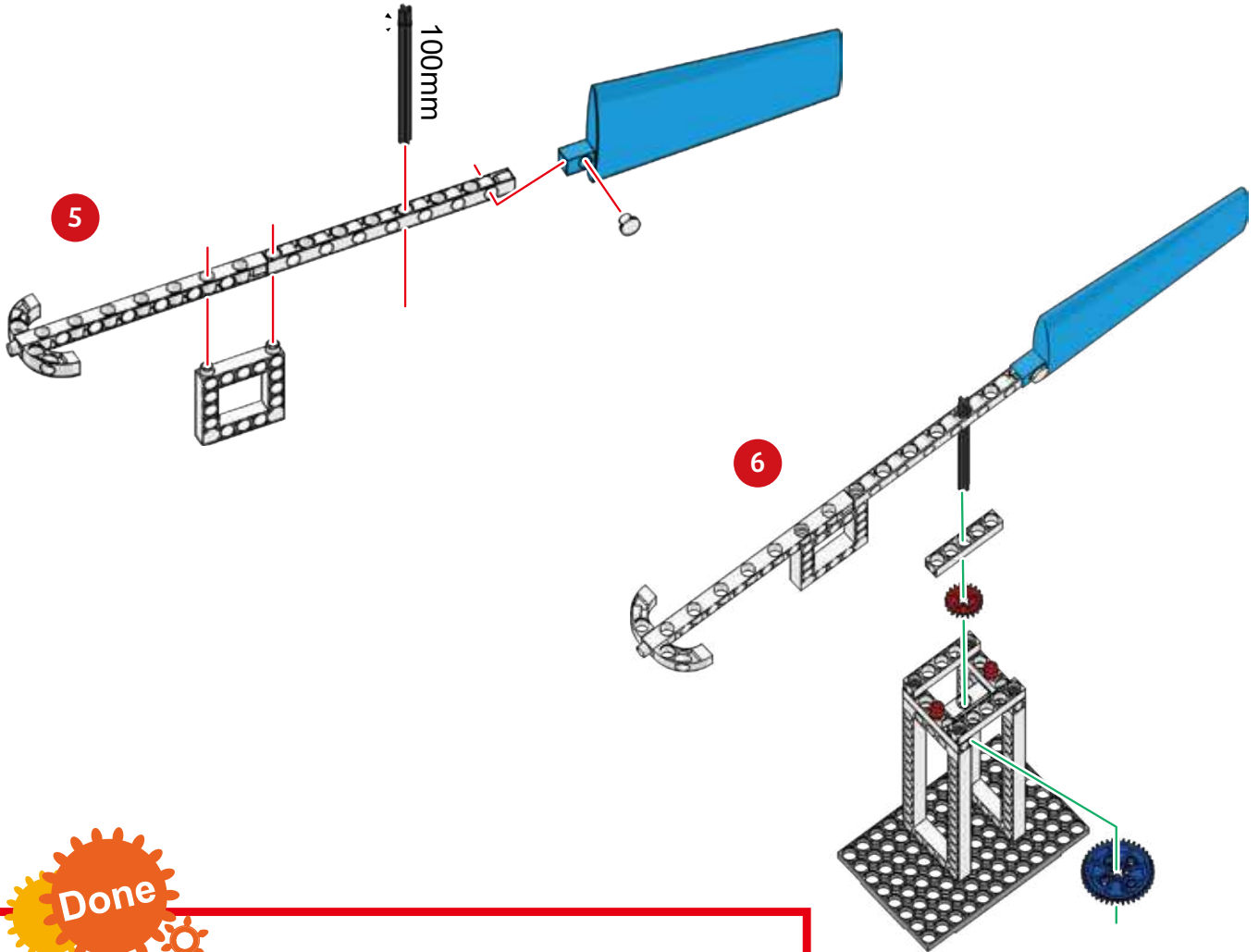

Done

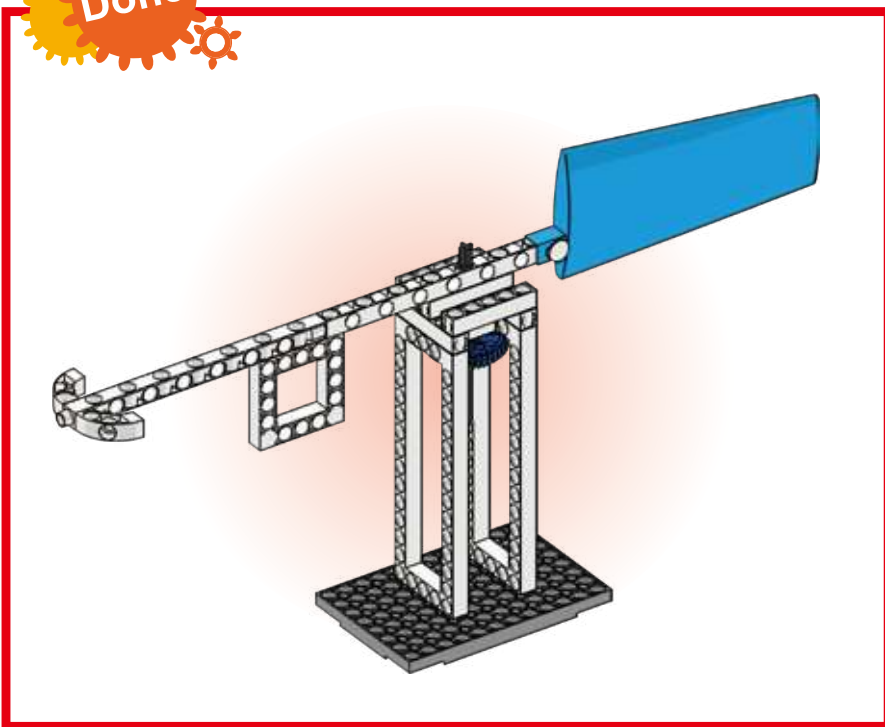

Model Operation
Video



What difference will it make to change the weight of the Wind Vane by adding more parts to it?

Blank writing area with horizontal dotted lines for notes.



How will you design a Wind Vane?

Blank writing area with horizontal dotted lines for notes.

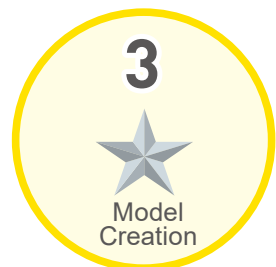
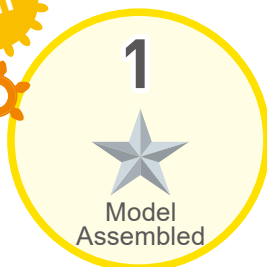



Gogo's father took a flight and his plane was due to land in a few hours. However, the city was struck by a strong typhoon. Gogo was anxious and asked his grandpa, "Will it be dangerous for the plane when there is typhoon?"



After assuring Gogo, Grandpa asked him, "Is it the rain or the wind first that affects the plane's safety?" Gogo answered with uncertainty: "Perhaps the wind".

His Grandpa replied, "All airports are equipped with Doppler radars which measure the wind speed using a non-contact method; furthermore, the wind speed and direction are determined when planes take off or land. So there is no problem in terms of safety. The only problem would be the arrival time which may be delayed due to weather conditions."

Daily Application

Wind power is a general way of describing wind-speed. Wind-speed is the preferred expression, and describes the distance the wind blows in one second (m/s). The International Wind Force Scale is issued by the International Meteorological Organization (WMO) on a scale from 0 to 17. It is derived from the Beaufort scale. An anemometer is a device used for measuring air velocity. There are many types anemometer; mechanical, optical, hot-wire, sonic, etc. In addition, the design of anemometers is constantly improving. Beginners can make a simple anemometer by combining the knowledge of hydromechanics and the simple pendulum, or by calculating the rotating speed of a propeller.



Brainstorming

How would you determine the force of the wind?

Parts List

2 	3 	4 	5 	6 	7 	8 	9 	12 	14
x1	x6	x14	x9	x3	x1	x5	x7	x3	x2
15 	17 	19 	20 	26 	29 	31 	38 	39 	
x3	x1	x2	x1	x1	x3	x1	x6	x1	

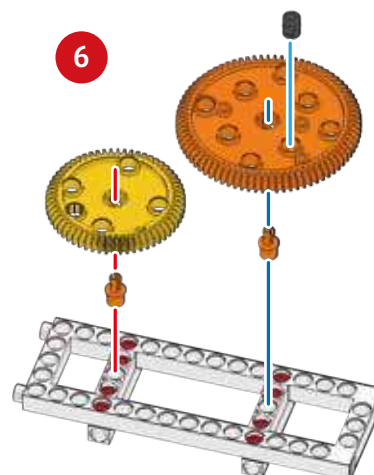
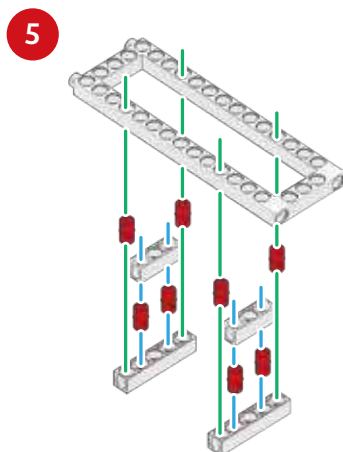
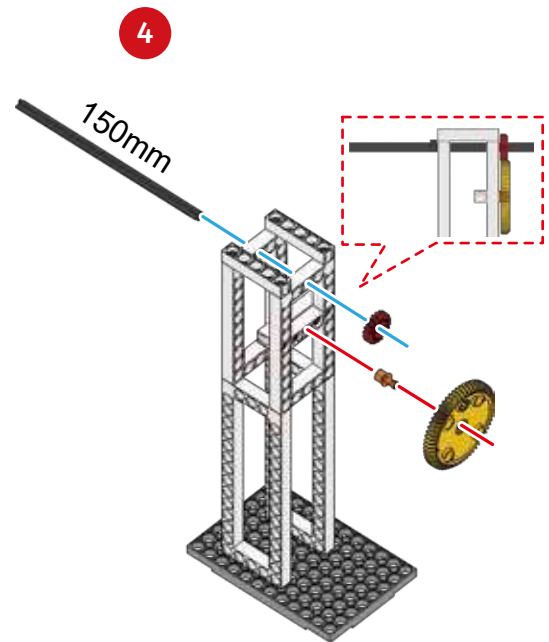
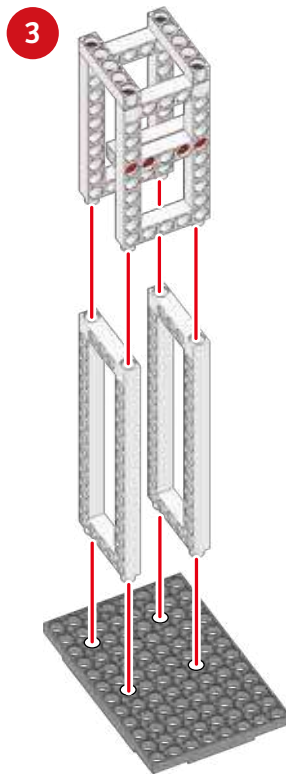
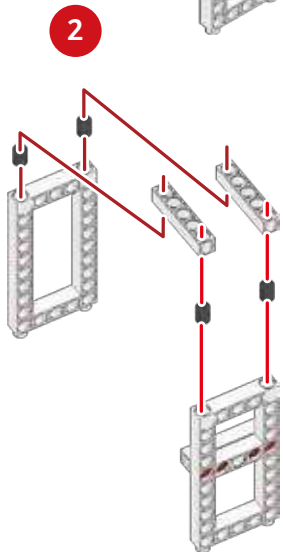
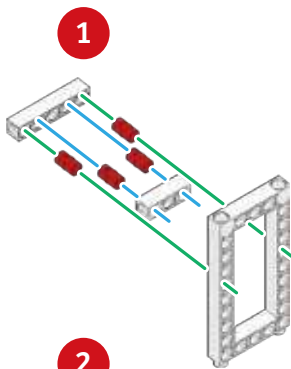

4

Wind Power Measurer

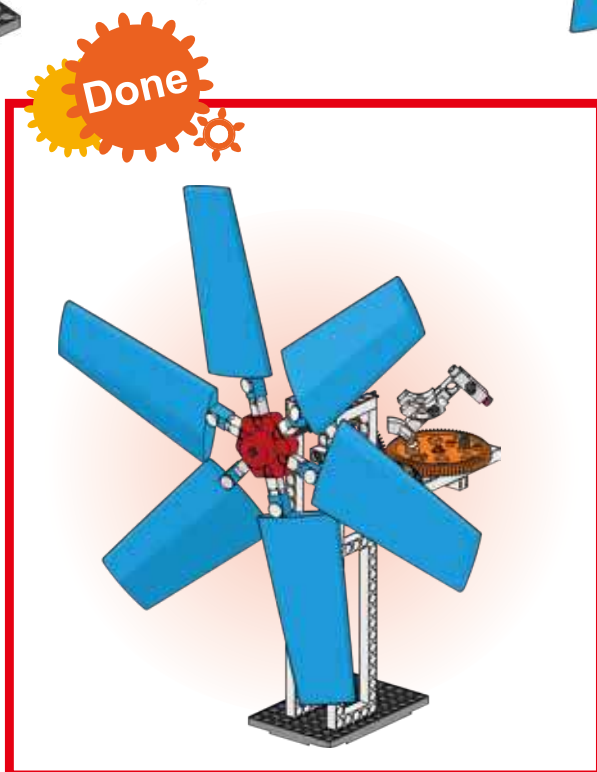
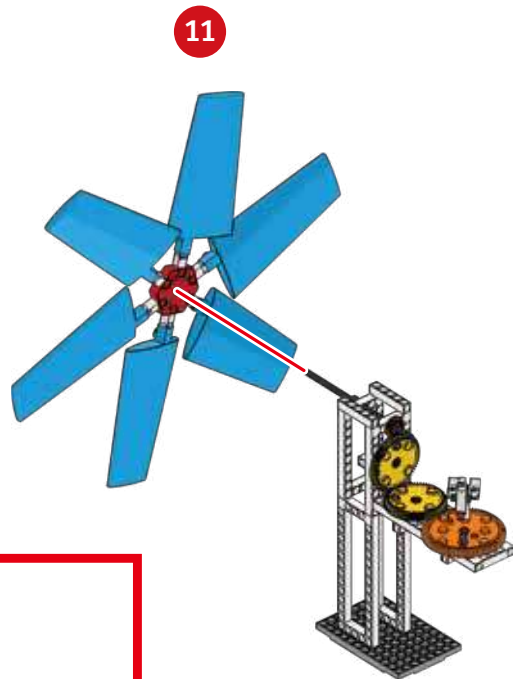
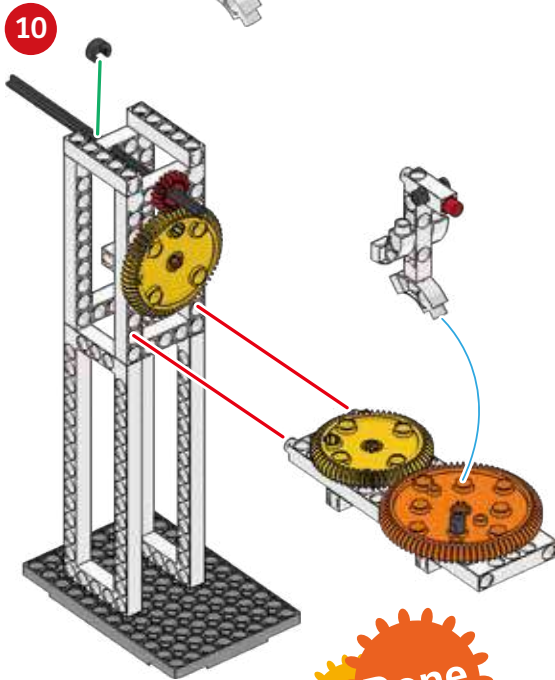
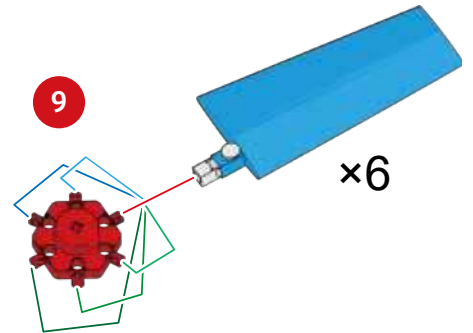
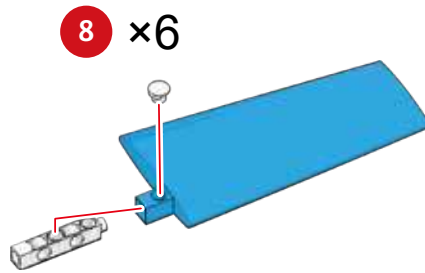
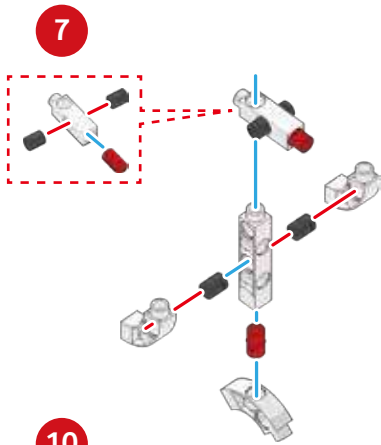

Model Operation Video



Use a one-minute timer and see how many times the bird on the gear spins at the max/middle/low speed settings of the fan.

.....

.....

.....

.....

.....



Modify your model by reducing the number of blades, how can you adjust to make it work?

The three angle templates



※ Refer to the figure on the left to adjust the windward angle of the blade.



Smart Manual
Web Service

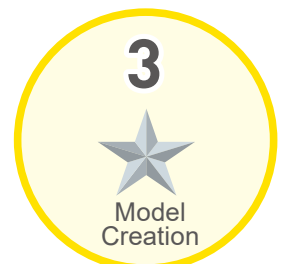
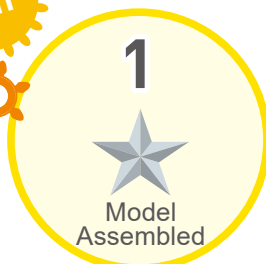

5

Monograph 1

Using the models and principles that you have learned about, try to design a mechanism that is able to measure both wind direction and power.



1. Hand-held Windmill



2. Hand Powered Fan



3. Wind Vane



4. Wind Power Measurer

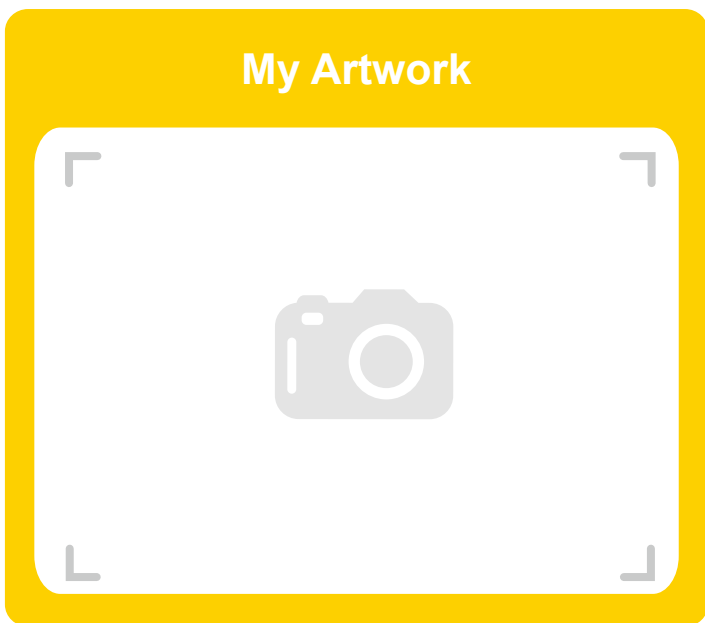
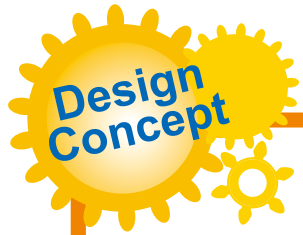



In the early 1600s, Dutchman Simon Stevin invented a two-masted sailing car. He integrated two-masted sails with a car body, an axle and wheels to make a sailing car a possible mode of transport. However, the vehicle could not move against the wind or without the wind. Moreover, the air flow and wind strength were such that the vehicle was not practical. Consequently, because of the high cost, heavy weight and poor

efficiency, the sailing car had no practical value and was forgotten.

By the 20th century, leisure sports became more popular. A New Zealander named Paul Beckett improved the invention. Beckett initially intended to create a portable wind-driven sport vehicle, usable by people of different ages and body conditions. Because of its reasonable price and easy operation, the lightweight and newly invented three-wheel sailing car became popular around the world.

Daily Application











This kind of sailing car with one wheel at the front and two at the rear is easier to control since it travels on land unlike the sail boat. The sailing car is designed with directions controlled by foot pedals and a sail controlled by hand. The car would speed up when the rope is tightly held. Conversely, the car may slow down when the rope is loosened to lessen the wind on the sail. Since the sailing car is light, it can travel on different surfaces like (beach) sand, parking lots, sports arenas and even ice.

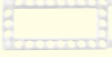

Brainstorming

People often make life more convenient with the help and power of nature. What facilities around derived functionality from natural sources?

Parts List

3	4	5	8	9	11	12	14	21
								
x2	x4	x2	x1	x2	x1	x2	x1	x2
22	24							
								
x2	x2							

※ P. 77~78 Paper Card - Sail

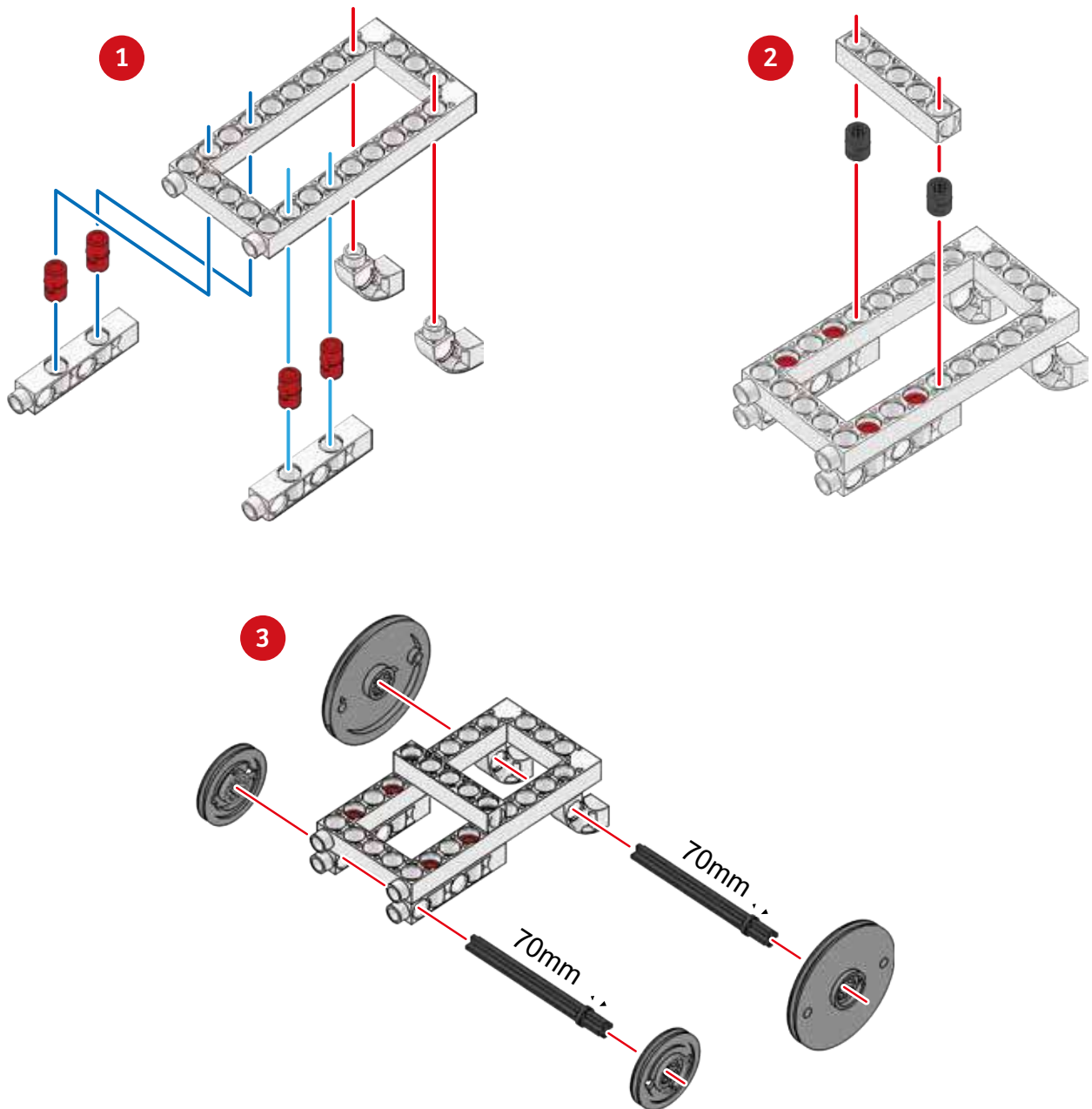

6

Sail Car

4-1 Single-sail Sail Car

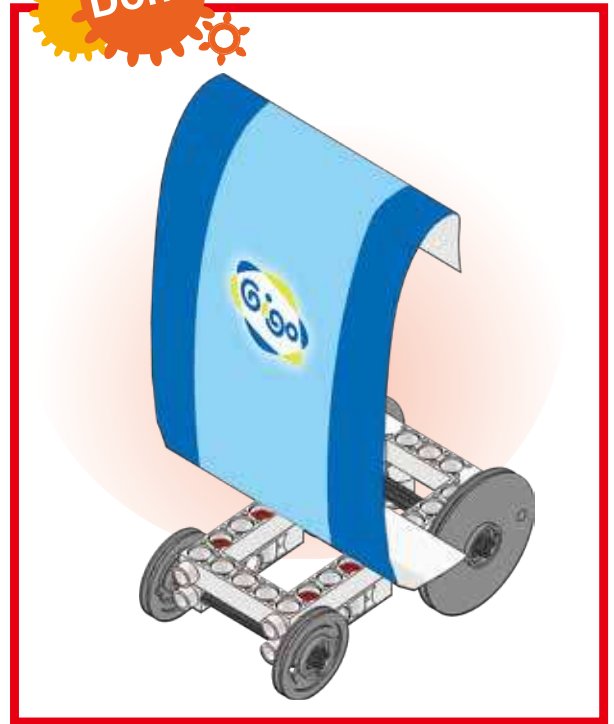
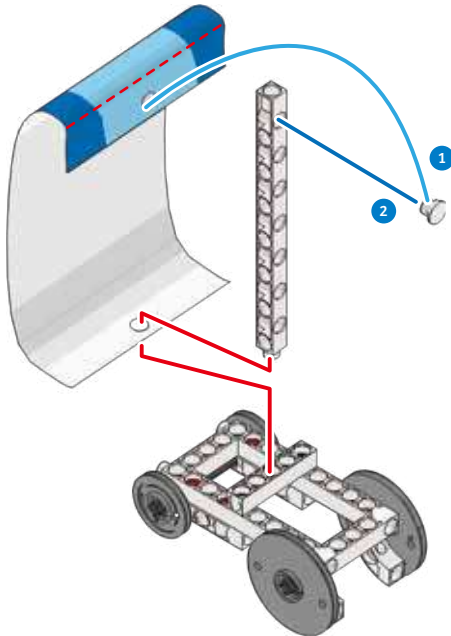

4-2 Windsurfing Sail Car

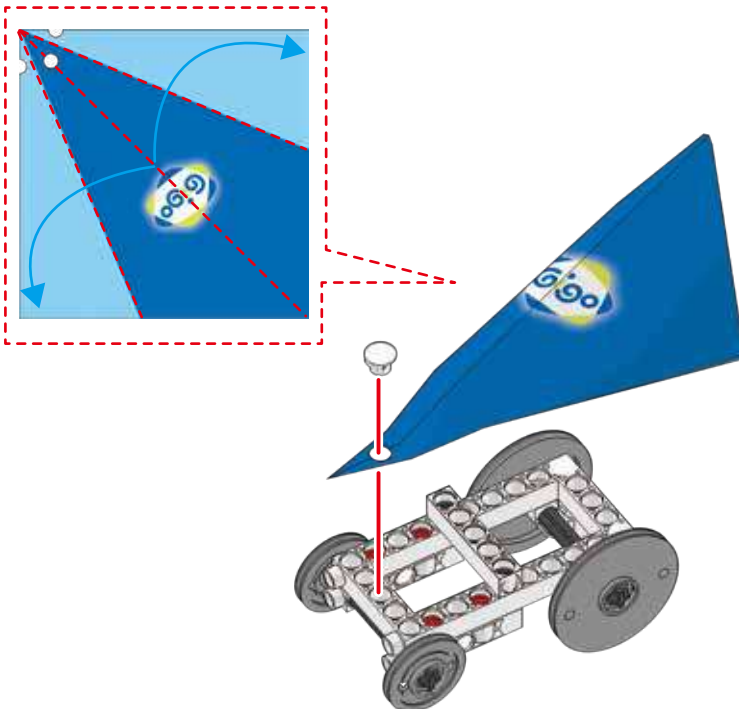

Model Operation
Video



With fixed paper thickness, car weight, and wind direction, which of the Sail Cars runs faster? Under what circumstances does a single-sail car/windsurfing sail car run faster?

Blank writing area with horizontal dotted lines for notes.



What could be changed in the Sail Car's operation when different materials are used in the sail?

Blank writing area with horizontal dotted lines for notes.

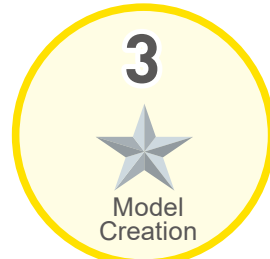
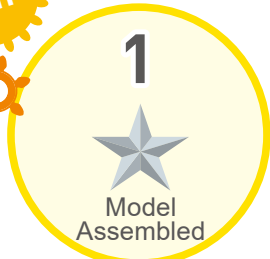



Gogo's school recently toured a science lab. The scientist showing them around used a dual-blade model to show them some facts about the relationship between wind and rotor blades.

To begin with, the model's blades were at 90 degrees to the axis of rotation, parallel to the ground, like a letter T. The exhaust edge of the blade was facing up. Next, the model was positioned so a breeze could blow in from the side, perpendicular to the model. Very little airflow was required to generate the

required rotational torque to move the blades. Even a small breeze could move them.

The scientist leading the tour then adjusted the angle of the two blades to about 120 degrees, like a letter Y. In this position, more torque was needed to rotate the blades. Again, when the blades were adjusted to an 80-degree angle, even more torque was needed to rotate the blades.

After listening to the speaker, Gogo asked, "If the two blades rotate on the same straight line along a rotational axis, like the letter I, will they still be able to rotate?" The scientist said, "Let's try it and find out!" They all discovered that it actually made it very difficult to turn the blades!

Daily Application

In physics, the force that makes an object rotate around a rotational axis, or a fulcrum, is called torque, i.e. a torsion force. The rotational torque is sometimes just called "torque" for short and it can make an object change its type of rotating movement. Pushing or dragging involves a force, while torsion involves torque. Torque is equal to the product of vector distance and force. A force applied at a right angle with a longer vector distance has the highest efficiency. That was why in the model the blade's windward side at a right angle to the wind generated the best effect.

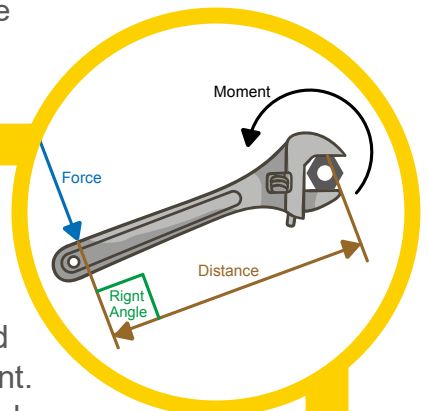

Brainstorming

In daily life, have you ever seen a gust of wind suddenly shutting a door?

Parts List

3



x2

4



x1

5



x4

7



x1

9



x3

13



x2

14



x1

15



x2

17



x1

26



x1

38



x2

39



x1

1

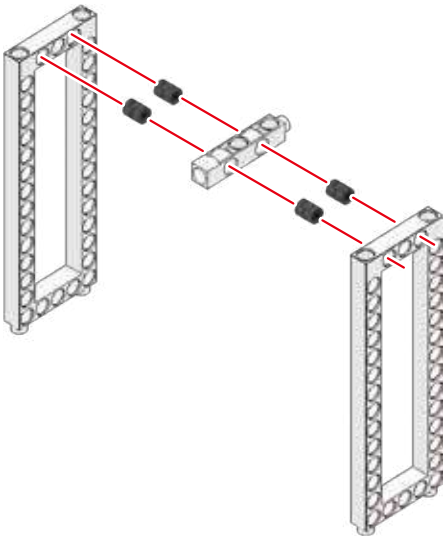

2

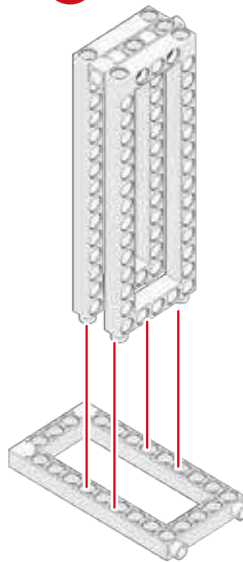

3

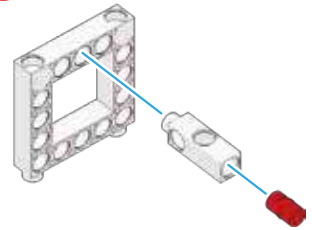

4

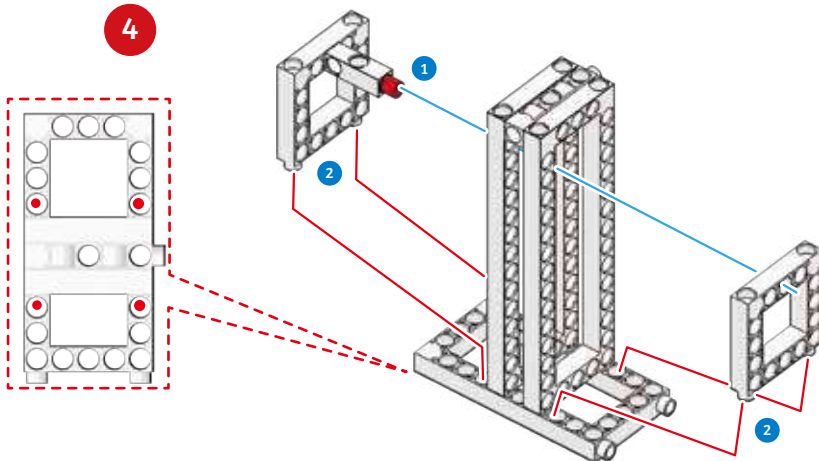

5 x2

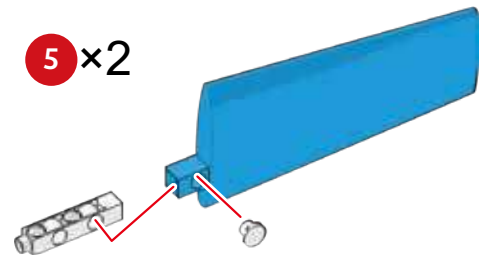

7

Fan Blade Tester

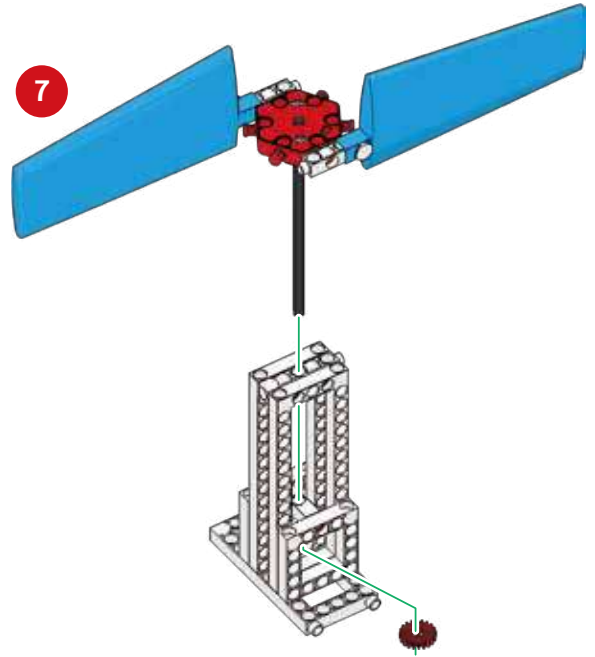
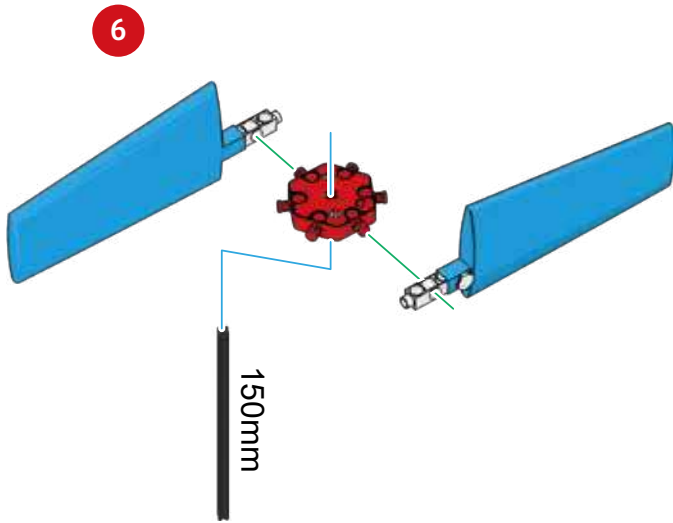

Type1

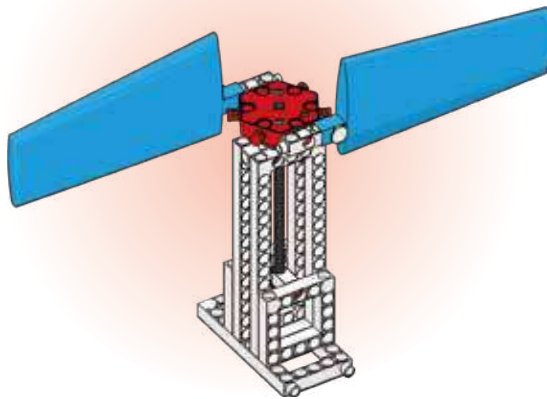

Type2

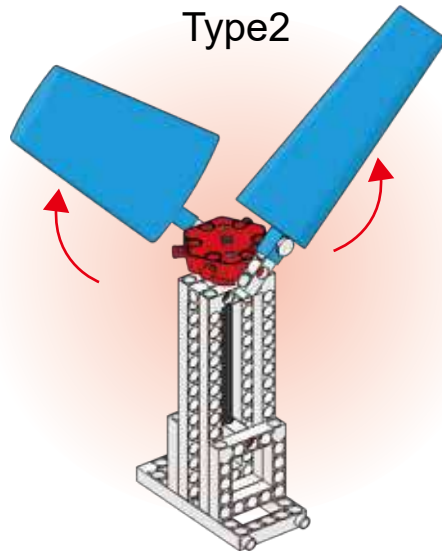

Model Operation
Video



Hands-on Experiment

Lay the blades flat at 180-degree, 120-degree and 90-degree angles with same wind velocity. See which angle makes the blades rotate. Next, observe the minimum angle required to drive the model under the same wind velocity.

.....

.....

.....

.....

.....

Use your imagination. How would you change the style of the Fan Blade Tester?



Hands-on Creativity

.....

.....



Evaluation



1



Model
Assembled

2



Experiment
Complete

3



Model
Creation



Gigi was looking through pictures of her dad visiting Germany's first offshore wind farm - Alpha Ventus, and she asked, "If there is wind everywhere, why do they have to build the wind turbines on the sea?"

Her daddy replied, "This is an offshore wind farm, it is different from the wind power plant which you are going to visit next week for your extracurricular school activity. Before setting up the wind turbines, engineers must make sure that there is a sufficient wind resource in the area. Since the source of wind energy is not stable, sometimes it is windy and sometimes not, the wind speed needs to reach a certain level to drive the wind turbine to generate electricity. Also, the machines are not 100% efficient, so not all wind force turns into electricity. When there are lots of wind turbines together they are called a wind farm.

However, wind farms make a disturbing low-frequency noise. They should always be built away from populated areas and bird habitats. A wind farm located in a coastal area is called an offshore wind field, while in an open land area it is called an onshore wind field. At the moment about 90% of wind farms are onshore wind farms."

Daily Application





















Ancient people observed nature and found ways to use it. The country that knows how to make the best use of wind resources is definitely the Netherlands. Wind resources are widely used there. The Dutch are famous for their wooden windmills that were and still are used for irrigation, drainage, milling grain and sawing timber. The premier function of the windmill is to use the turning of the large paddles into different kinds of power for various machines. Thus windmills can be used to grind, blend, stir and pump.



Brainstorming

What tools do you use to stir food?

Parts List

2  x1	3  x6	4  x8	5  x2	6  x1	7  x2	8  x4	9  x6	13  x1	14  x2	15  x2
17  x1	19  x1	20  x1	26  x2	27  x1	29  x1	31  x1	38  x6	39  x1		

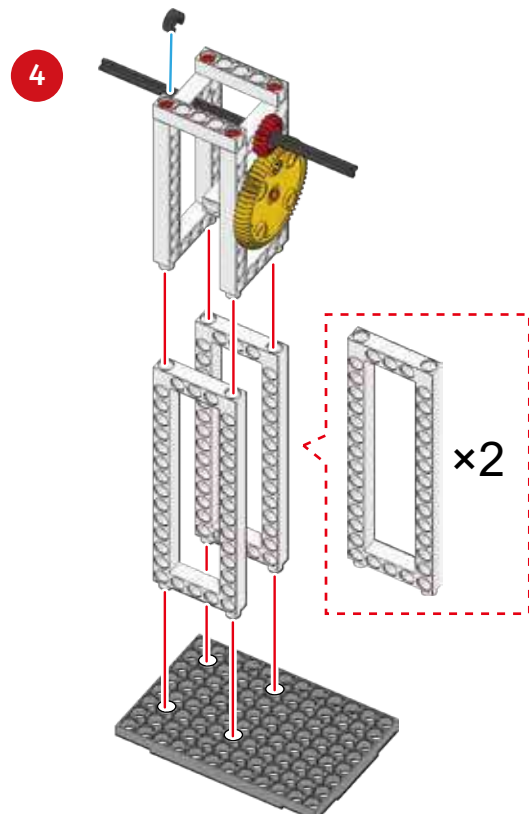
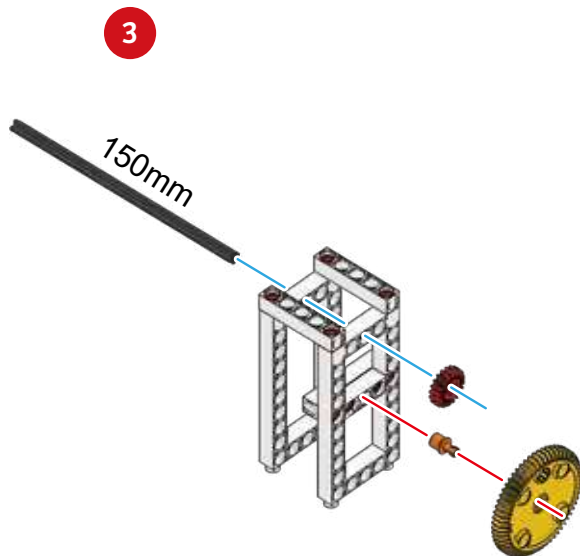
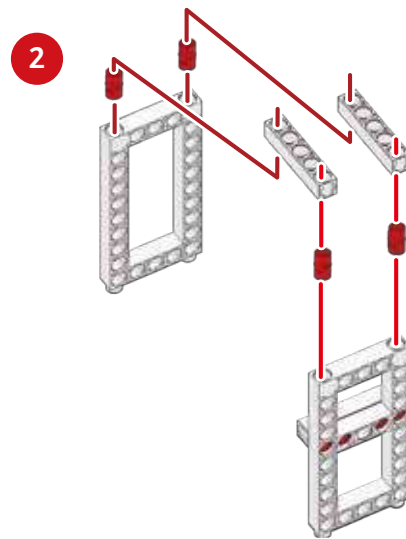
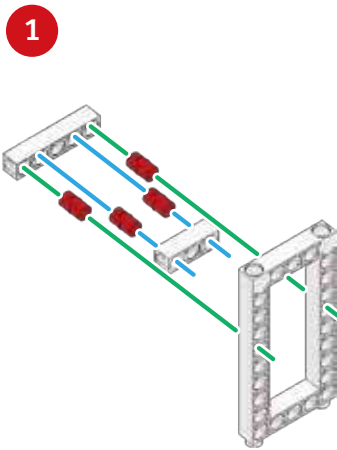

8

Wind Powered Whisk

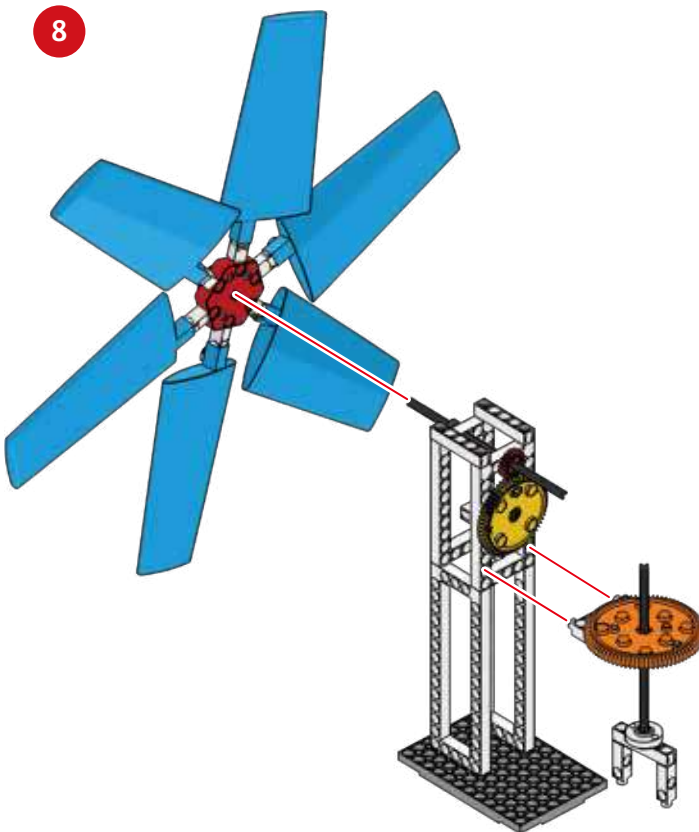
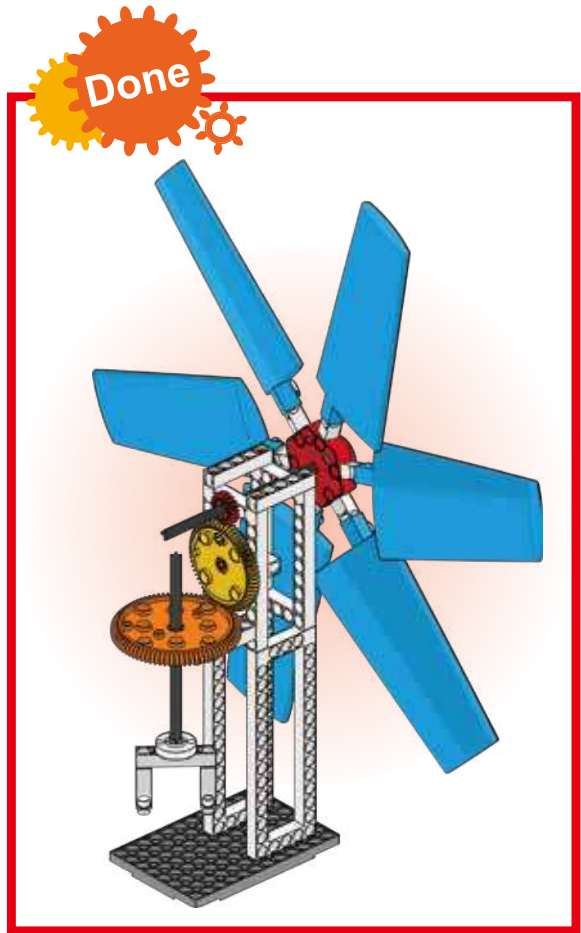
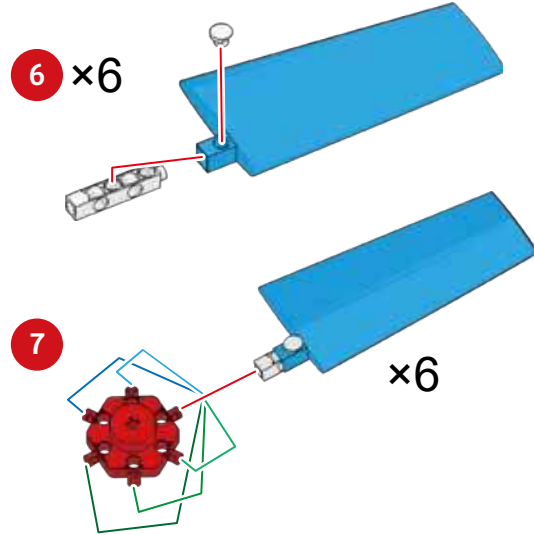
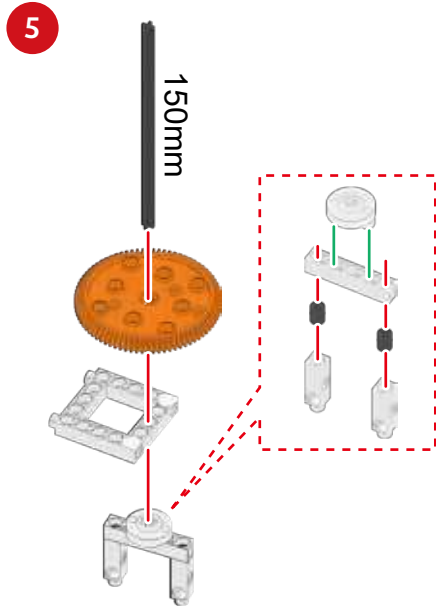

Model Operation Video



Adjust the output speed of the Wind Powered Whisk by using different gear sets.

.....

.....

.....

.....

.....



Change your Wind Powered Whisk into a different kind of mechanical tool by removing the blades or putting different attachments on it.

.....

.....

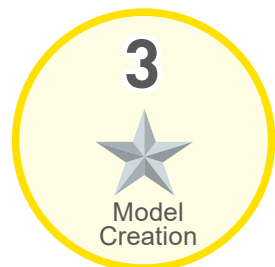
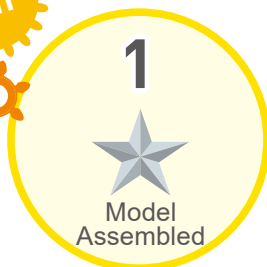



After hearing about a typhoon in the news, Gogo and his grandpa went to the supermarket to buy food supplies.

While approaching a construction site, Gogo noticed from a distance that the long arm of a crane had been broken by the wind. Gogo was curious and asked Grandpa about it. “Why is the crane’s long-arm so weak that it couldn’t withstand the strong wind? The typhoon hasn’t even arrived yet.”

Grandpa did not reply immediately but asked Gogo, “Why are large wind powered generators installed on high towers?” Gogo recalled that it was because the wind speed above ground is higher than on the ground. He then understood why the long arm broke, it was due to the wind speed being higher further from the ground.

Daily Application

With modern technology, weather forecasts can be confirmed ahead of time. For instance, warnings can be given if there is a typhoon coming.



















It is necessary to improve meteorological detection to prevent damage due to strong winds. Consequently, we can detect strong wind through changes in the rotational speed of a propeller. A mechanical or electrical facility can then be used to trigger an early warning indicator. The simplest weather vanes can also be used as a strong wind warning indicator. Nowadays, a weather vane is often used in smaller airports or on parachute training grounds where funds are limited. This weather vane swings aggressively to warn people when a strong wind is coming.



Brainstorming

What disasters may be caused by typhoons?

Parts List

2  x1	3  x6	4  x6	7  x2	8  x3	9  x6	11  x1	15  x4	17  x2	
18  x2	19  x2	24  x1	25  x2	31  x2	32  x3	33  x1	34  x3	38  x6	39  x1

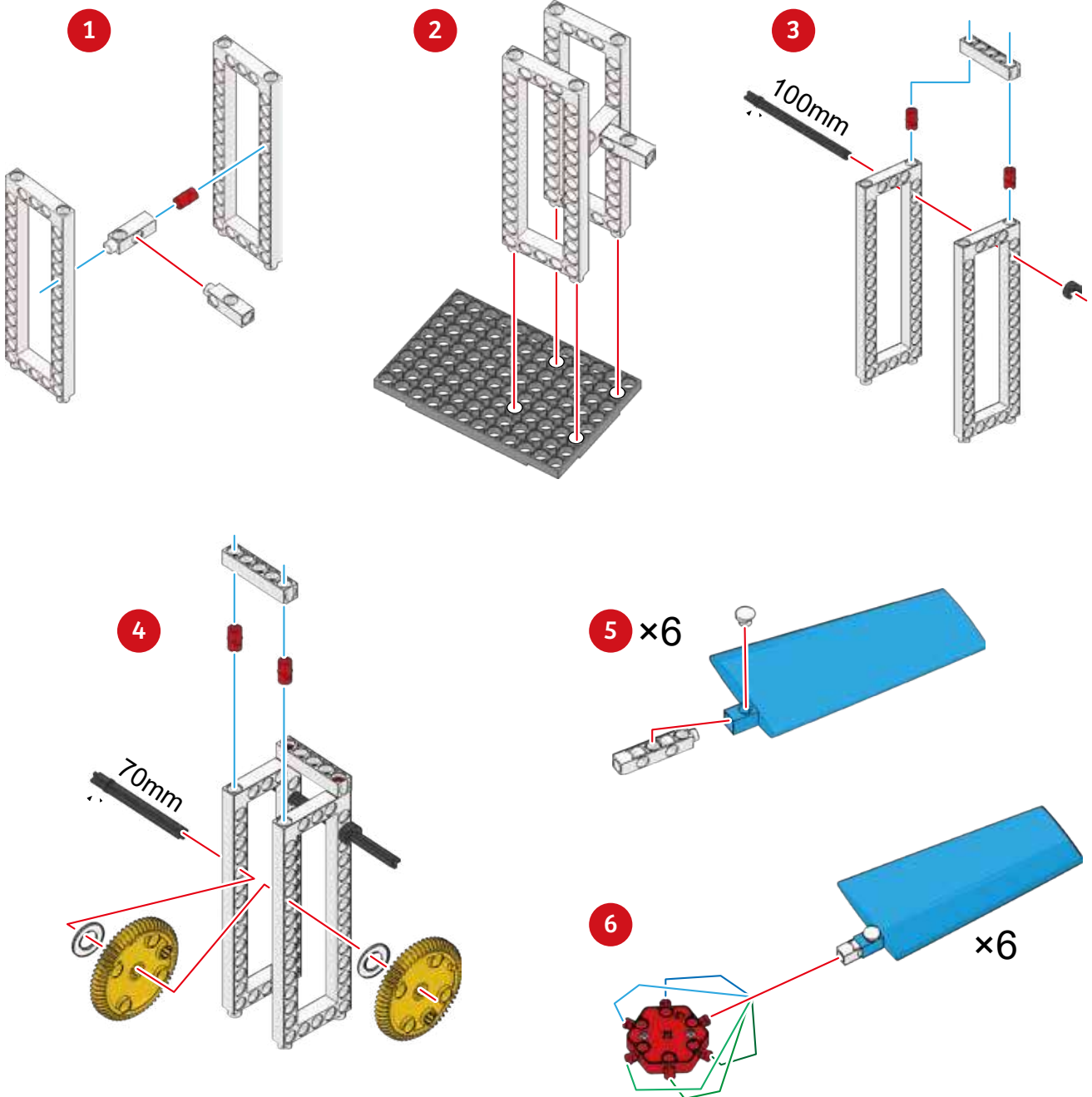

9

Strong Wind Warning Indicator

7

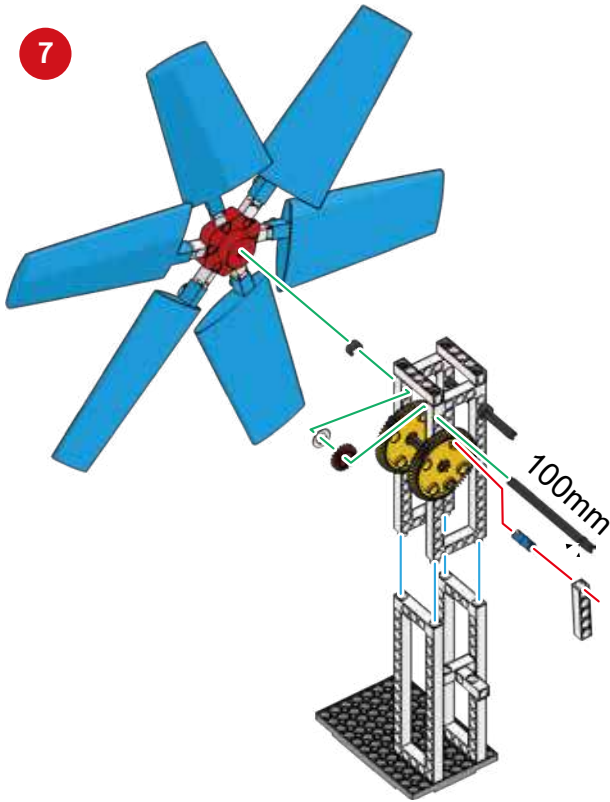

8

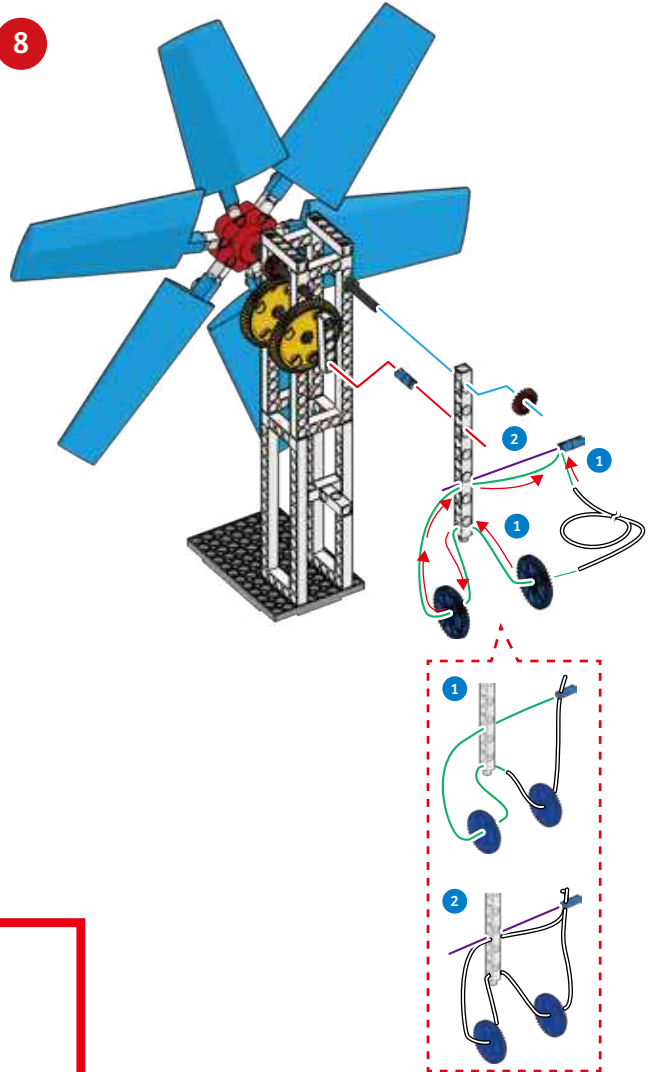

Done

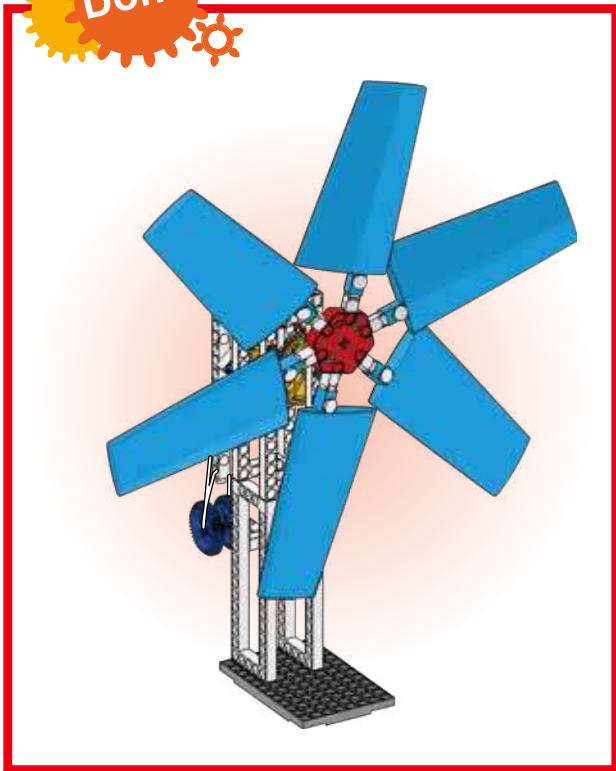

Model Operation Video



How strong does the wind have to be to trigger a chime for a strong wind alert?

Blank writing area with horizontal dotted lines for notes.



How can you design a strong wind alert that is easy to activate?

Blank writing area with horizontal dotted lines for notes.

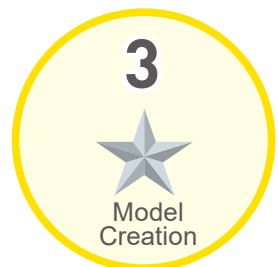
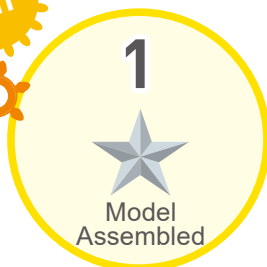

10 Monograph 2

Please design a wind powered tool using a principle or model you've learned about.



6. Sail Car



7. Fan Blade Tester



8. Wind-powered Whisk



9. Strong Wind Warning Indicator

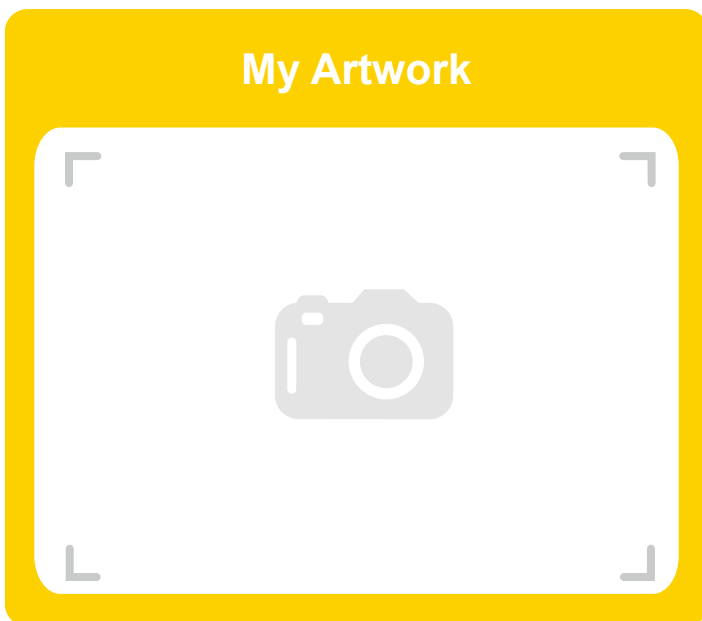
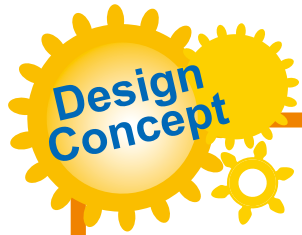



Gigi joined an off-campus activity that involved visiting a wind farm. When the tour bus reached the mountain, Gigi saw windmills that had three blades and were different from the electric fans she had at home which had four blades.

Gigi was curious and asked the teacher why windmills for power generation only have three blades. The teacher said that different turbines had different numbers and types of

blade. They are also used for different purposes. One with more blades is called a low-speed turbine it has greater torque, it starts at a low wind speed, which is useful for lifting water, and there can be as many as 12 to 24 blades. In contrast, windmills with fewer blades are called high-speed turbines.

Experimental tests showed that windmills with three blades could produce optimum economic efficiency, since they could produce a higher rotor power coefficient during high-speed operation. Moreover, fewer blades made them lighter than those with more blades, so they were ideal for power generation.

















Daily Application

A strong windmill generator is usually installed on a high tower, since the air velocity above ground is greater than that close to the surface. Generally, a larger blade can improve generation due to the increased thrust, also it reduces risk and improves economic efficiency under weak wind conditions. If the total blade area remains the same, the more slender the blade is the greater the power generation efficiency. Moreover, longer blades can generate enough torque to drive the power generator even under weak wind conditions.

Brainstorming

What shapes of blades have you seen?

Parts List

2  x1	4  x10	6  x1	7  x2	8  x2	11  x2	14  x4	15  x4
17  x1	19  x1	25  x1	26  x1	30  x1	31  x1	37  x3	39  x1

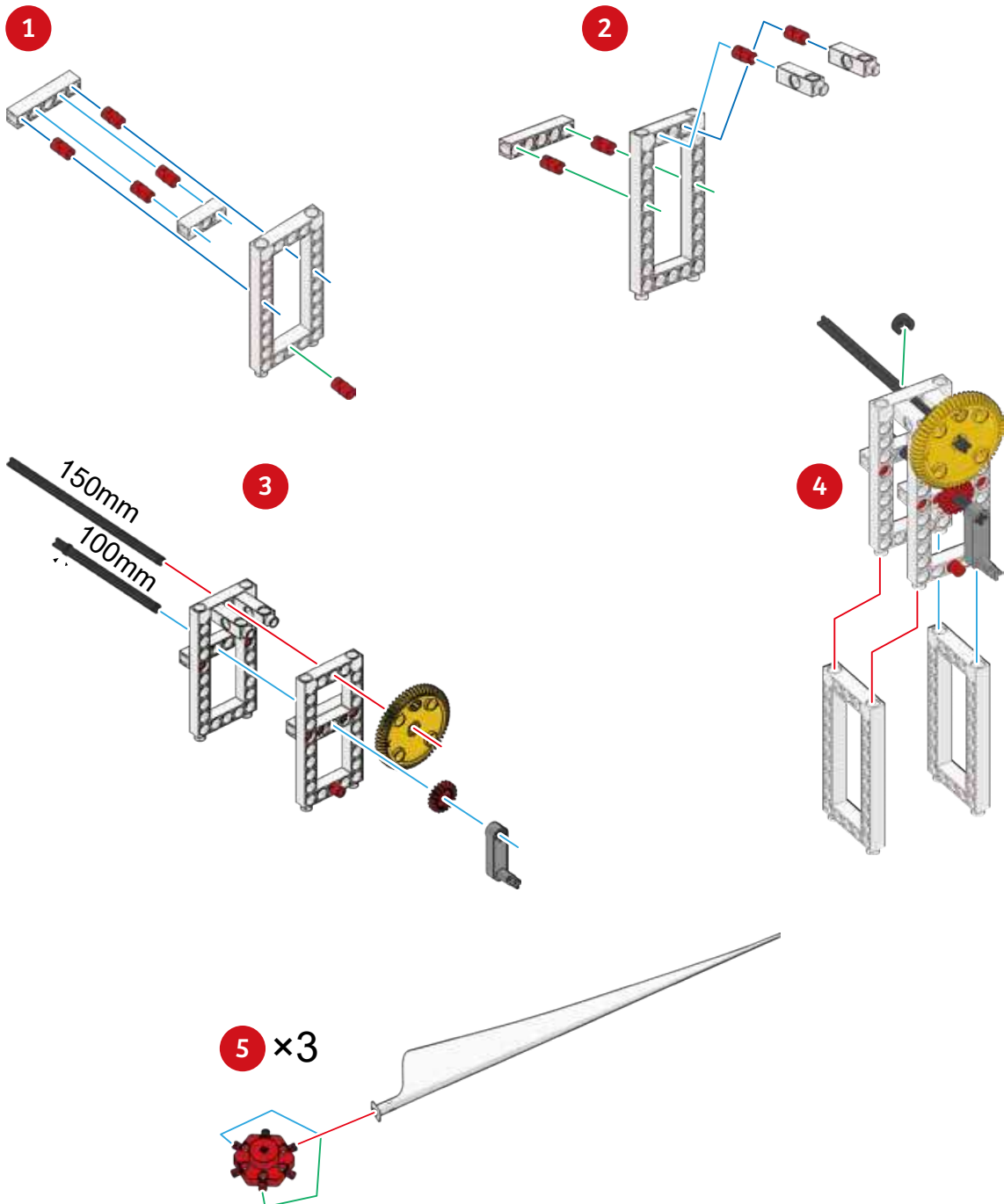

11

Long-blade Windmill

6

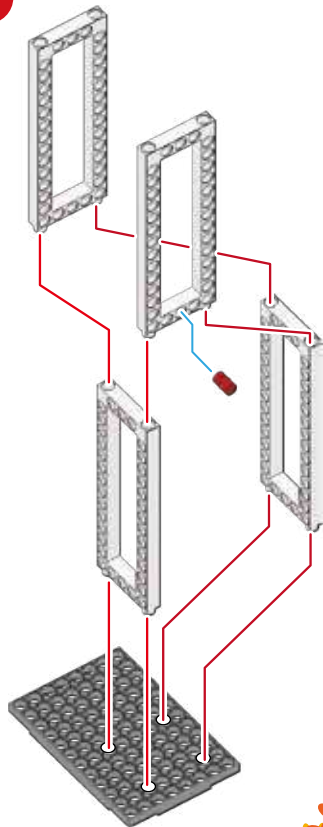

7

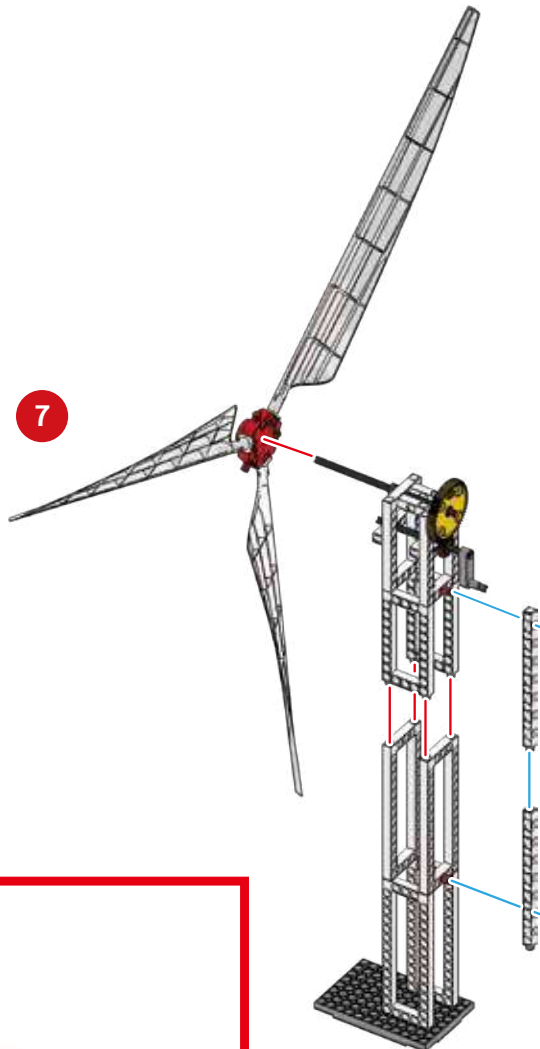

Done

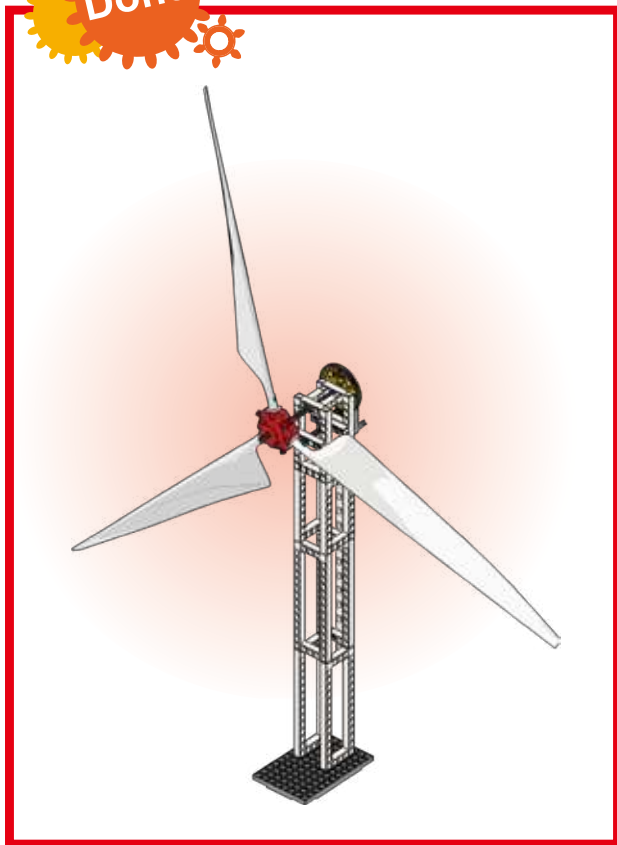

Model Operation
Video



See how many times per minute the blades rotate, also see how strong the wind must be to start them moving.

Handwriting practice area with five horizontal dotted lines.

How would you like to change the style of your Long-blade Windmill?



Handwriting practice area with two horizontal dotted lines.

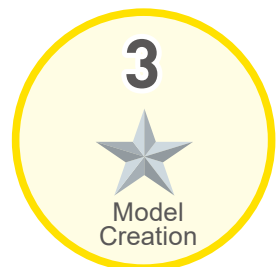
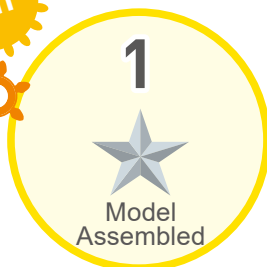

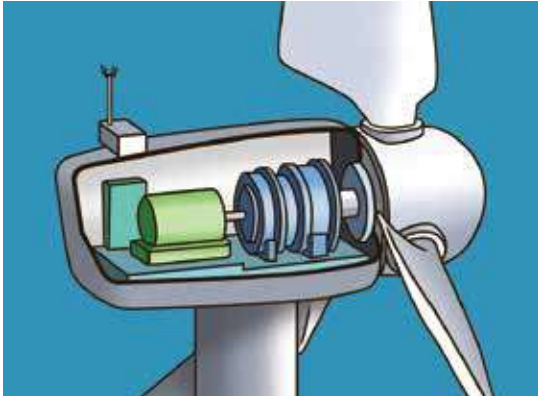

During Gogo's visit to the wind farm, the tour guide mentioned that the windmill generators were a very new design. Later on, when Gogo climbed up the high tower, he observed that the area was spacious and there was relatively little noise in the machine room.

The guide explained that the generators were driven directly by the wind with no variable-speed motor. These machines were called direct-driven windmill generators. With the high failure rate of variable-speed motors that use a gearbox, direct-driven windmill generators have become popular because of their improved efficiency, low noise, long service life and reduced maintenance costs.

Daily Application

Since windmill generators cannot convert all the wind energy, their design may affect the amount of electricity derived from kinetic wind energy. This is called output efficiency.

The output efficiency is greatly affected by the blade design and rotation speed. Since blade design was previously discussed, we now focus on the influence of the rotation speed on output efficiency.

Wind flow over the Earth's surface is unstable, so the rotation speed of a windmill may vary with the strength of the wind. Generally, an increased rotation speed may produce higher output efficiency. Most large scale windmill generators may adjust rotation speed through a variable-speed motor or blade adjustment mechanism, to maintain optimal operation.

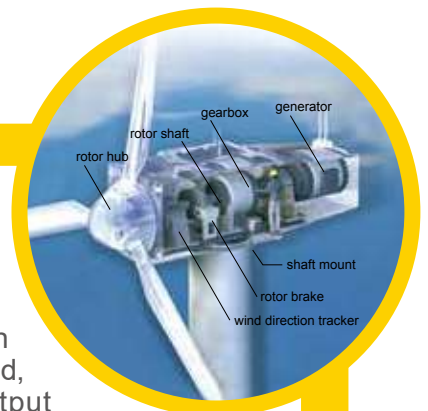

Brainstorming

When do we need to adjust the rotation speed of a windmill?

12

Variable-speed Windmill

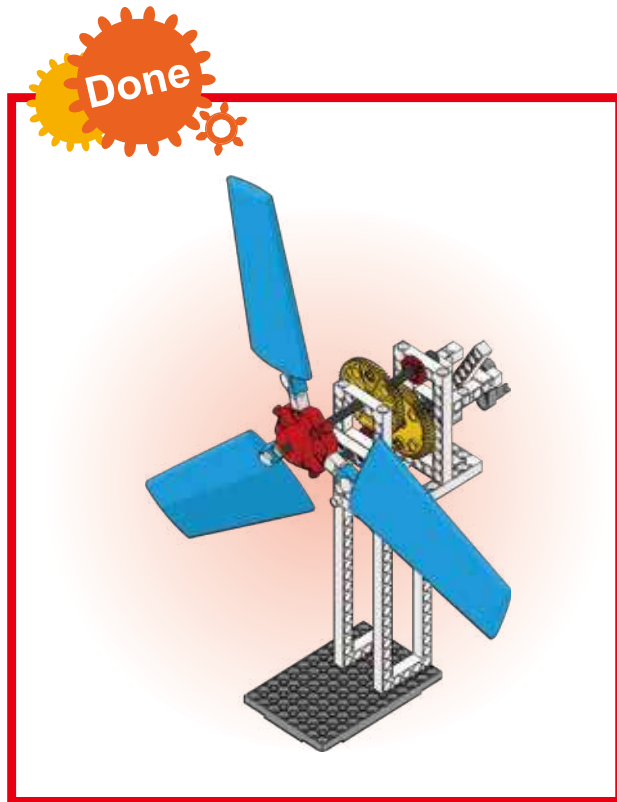
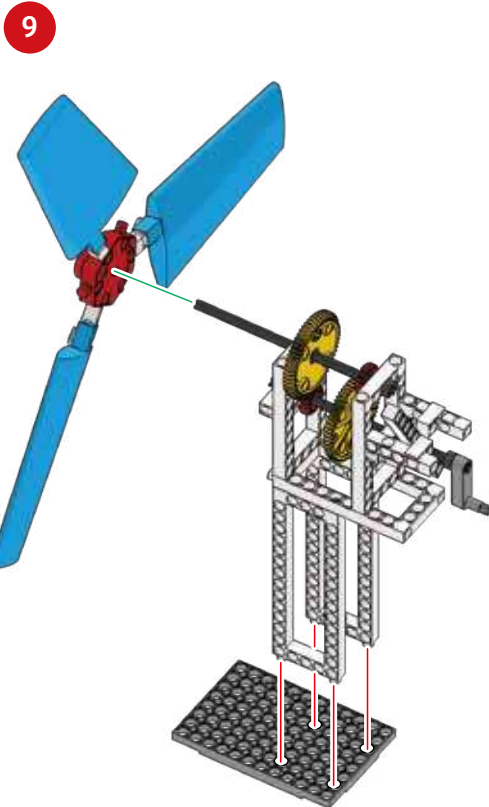
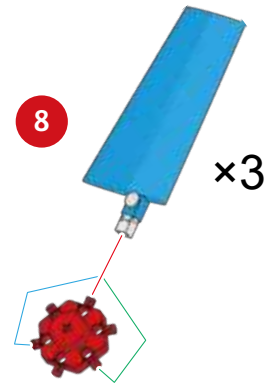
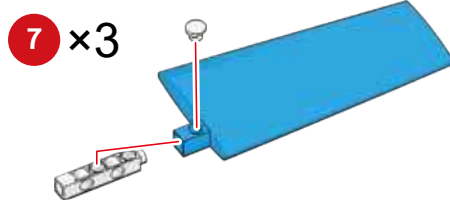
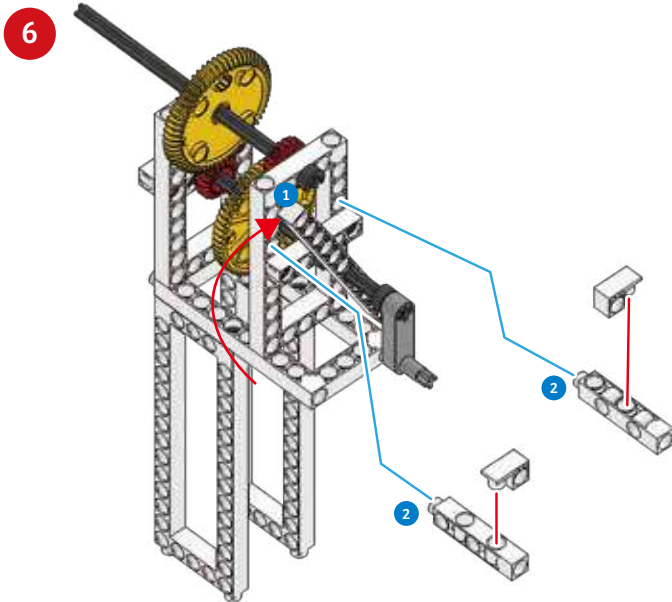

Model Operation
Video



Compare two windmills with different output power. What is the difference in their rotation speed?

Blank writing area with horizontal dotted lines for notes.



Design a windmill with different style using the existing materials.

Blank writing area with horizontal dotted lines for notes.

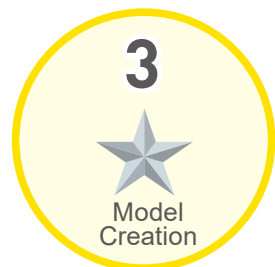
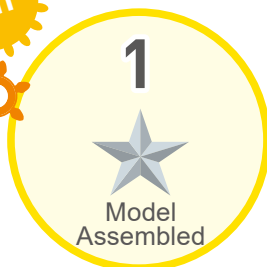

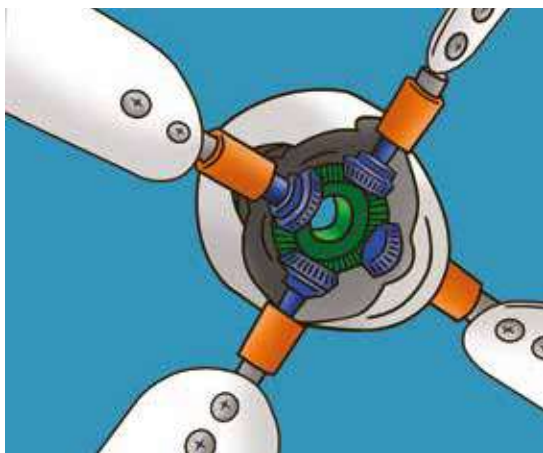

A wind mechanism is the construction space for wind powered machines, a physical structure which protects the machine parts and support its regular operation. In wind power generators, it takes the role of maintaining the normal operation of the wind turbine, and protects it from damage by strong wind. One of the most challenging things is blade maintenance.

Power generators run at high speed under strong wind, when it is too strong (larger than 12 m/s), a traditional mechanism structure turns the blade surfaces from windward to leeward, in order to protect the generator. When the wind speed is over 25 m/s, it will shut down completely.

The new mechanism has a variable angle design. When the blades come in contact with strong wind, a rotating torsion centered on the axial blade may adjust the blade gear and change the blade angle automatically. This helps prevent damage and continues to generate power.

Daily Application

Since ancient times, people have known to utilize wind power. There should always be a space for the equipment, with a solid structure that protects mechanisms and supports normal operations. For instance, people designed a wind powered mechanism to drive away birds that feed on crops. This is called a wind powered scarecrow, which is a simple wind energy mechanism. In terms of manufacturing, people use local materials like straw to create the shape of a man and set it up among the crops. The scarecrow then moves and waves when the wind blows, scaring the birds away.



Brainstorming

Which objects are powered by the wind?

Parts List

2	3	4	5	6	7	8	9	10	11	12	13
x1	x3	x7	x10	x1	x2	x4	x3	x1	x1	x1	x2
15	17	19	20	25	26	29	31	32	38	39	
x5	x2	x1	x1	x1	x1	x2	x1	x1	x3	x1	

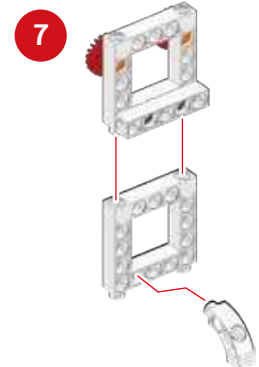
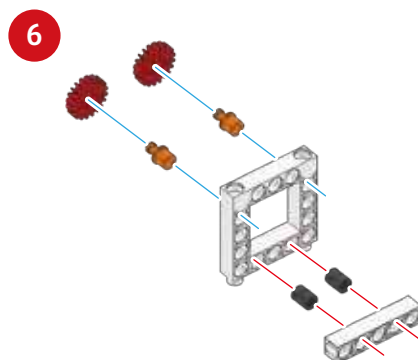
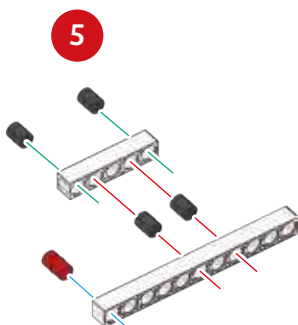
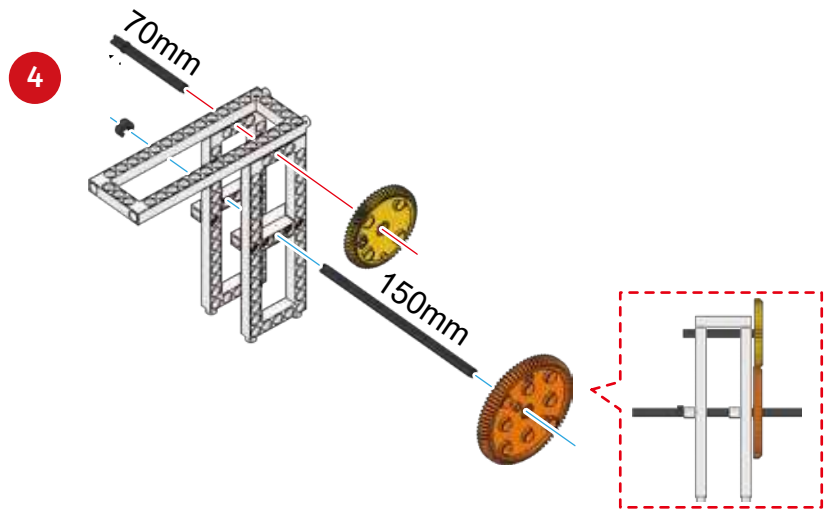
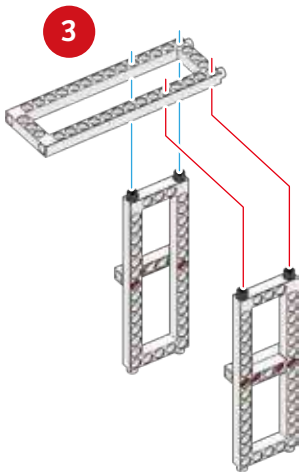
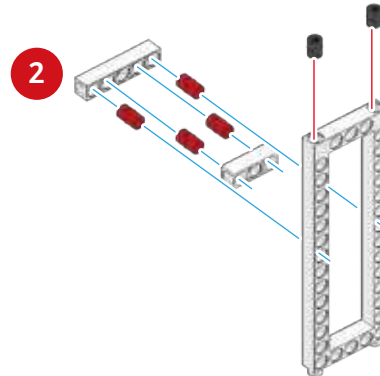
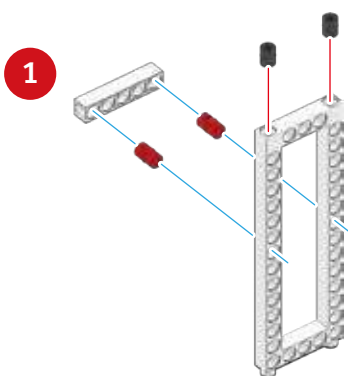

13

Wind-powered Scarecrow

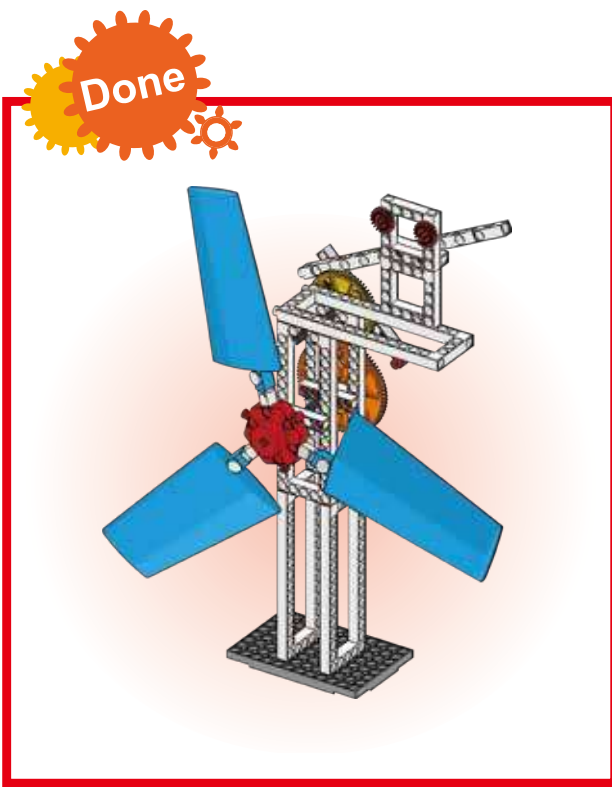
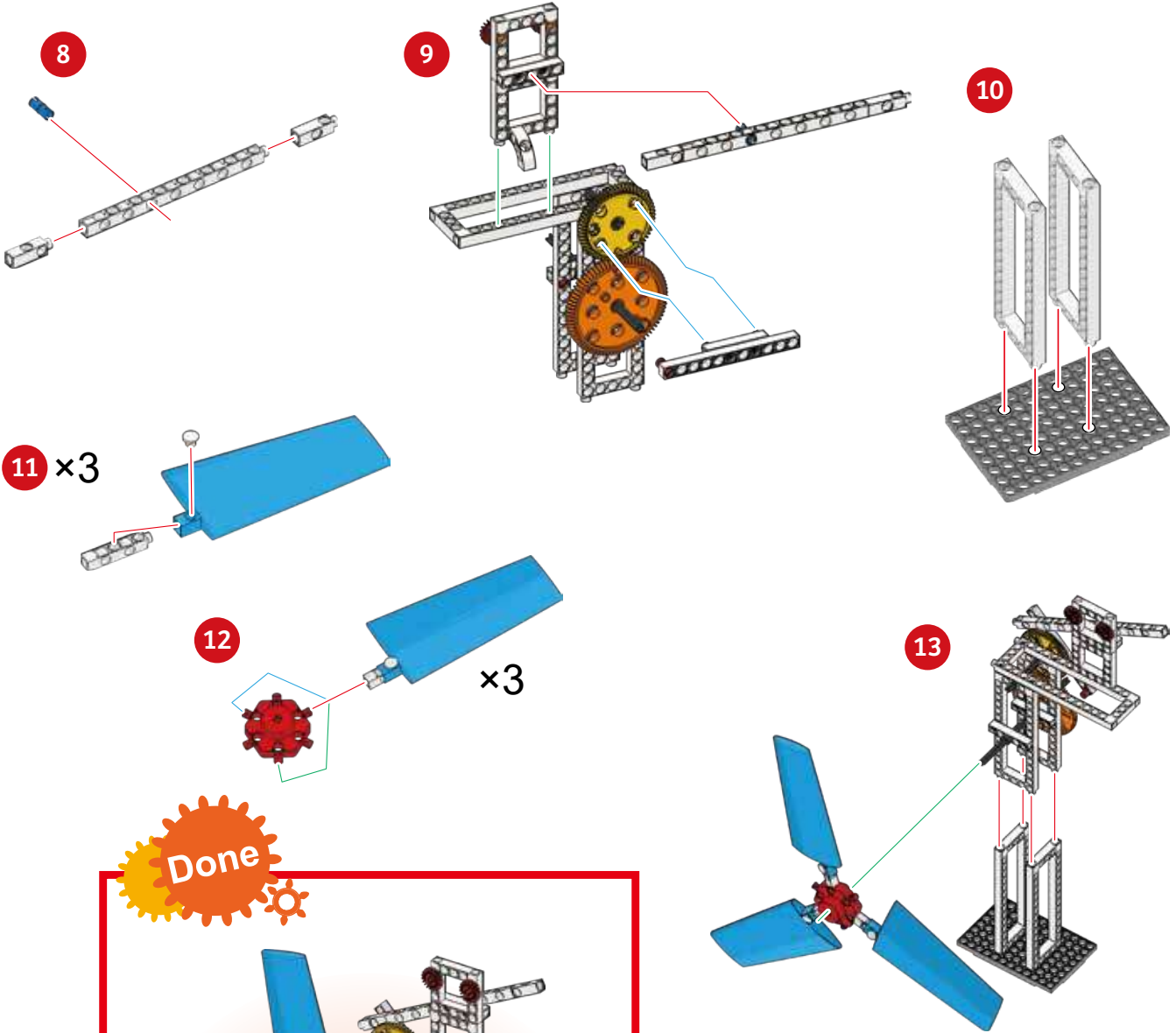

Model Operation Video



Make a scarecrow shape on the swinging structure.

Blank writing area with five horizontal dotted lines for notes.



How do you make the scarecrow swing when the blades rotate?

Blank writing area with two horizontal dotted lines for notes.

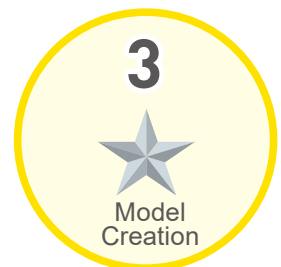
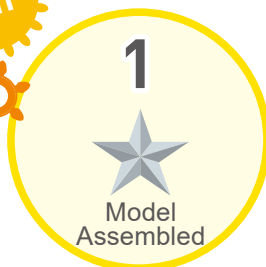



Gogo felt hot inside after being outside in the park with his kite, so he turned on the electric fan and played with the kite at the same time.

Seeing the kite swing as the cool air blew, Gogo suddenly thought of the electric fans in school that were used to drive the electric generator, so he got curious and asked Grandpa whether a kite could be used to generate power.

Grandpa replied: “You are really creative coming up with ideas like that. Recently, some researchers have invented a new kite wind generator that made enough energy to power a merry-go-round. The merry-go-round also generated electricity by induction from the rotation.”

Daily Application

Electricity generated by wind-power has many stages, they are as follows: (1) rotation of the blades; (2) causes the magnets in the generator to rotate; (3) the magnetic turning causes the magnetic field lines to break from the magnetic field lines of the stationary coil; (4) this creates current/power which flows from the output leads; (5) the magnetic power generation is similar in principle to Faraday electromagnetic induction. Wind power is a type of energy conversion, that converts wind energy into mechanical energy and then into electrical energy. Even though wind power is mostly natural, clean, pollution-free and widely distributed, wind instability affects the power generation performance, it also produces noise problems which affects the habitat of birds. The global trend is towards offshore wind farms, to use stronger winds and save space and animal habitats on land.



Brainstorming

Have you ever seen a large windmill by the sea? Do you know its function?

Parts List

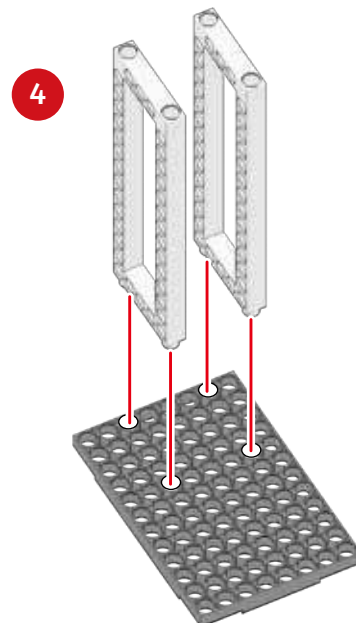
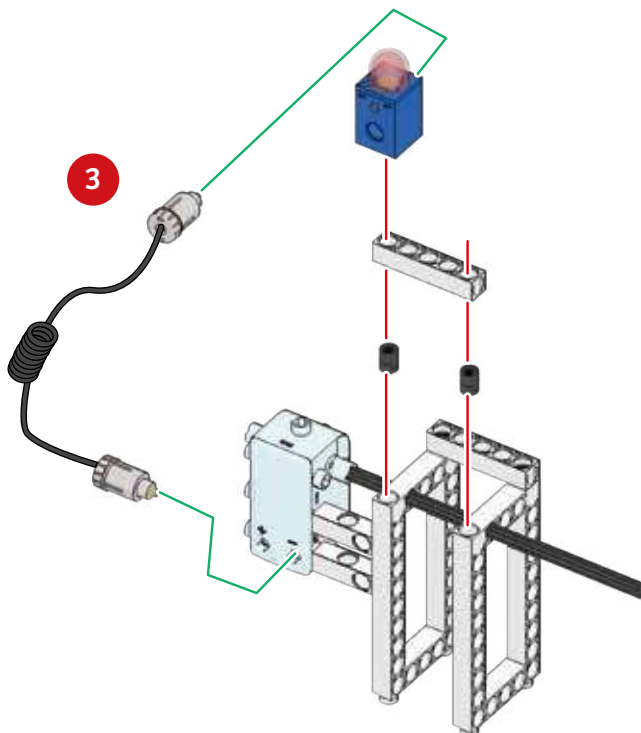
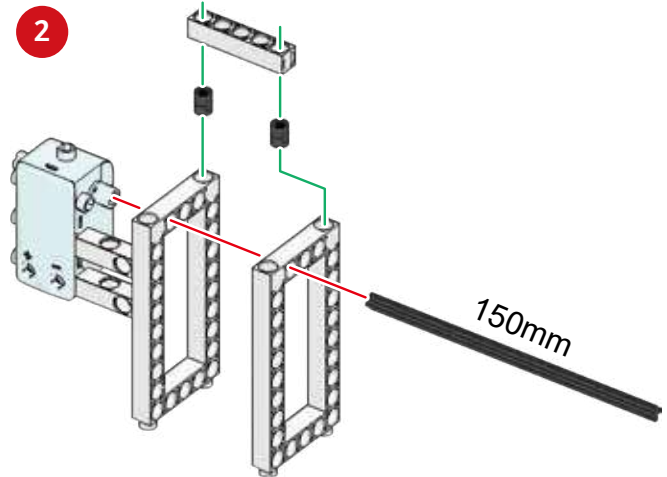
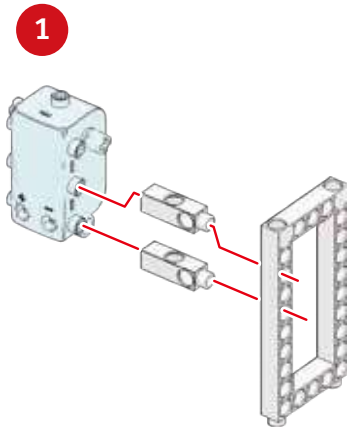
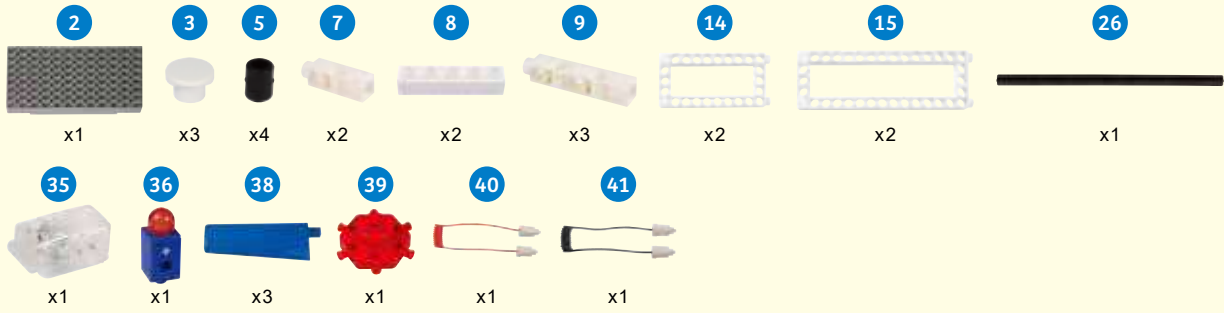

14

Windmill Generator

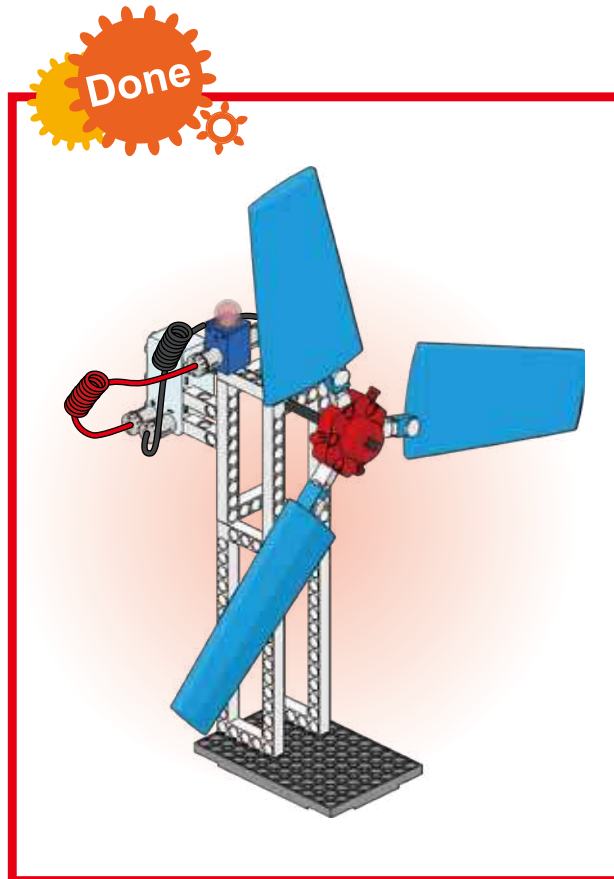
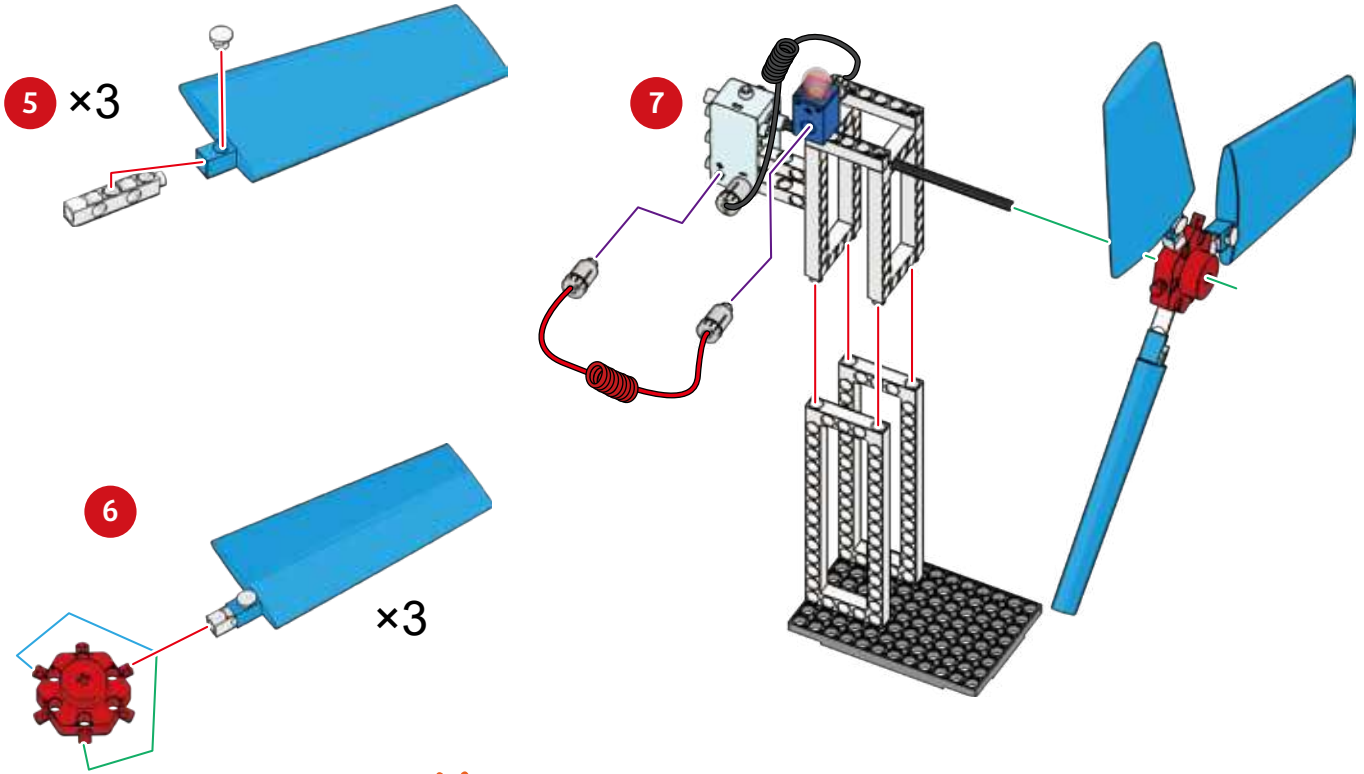

Model Operation
Video



Which direction is the wind coming from? Look for it and make a record when the bulb lights up.

Blank writing area with five horizontal dotted lines for recording observations.

Use wind turbines to test the strength of the wind throughout an area and make a wind power map.



Blank writing area with two horizontal dotted lines for recording observations.

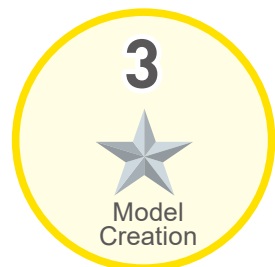
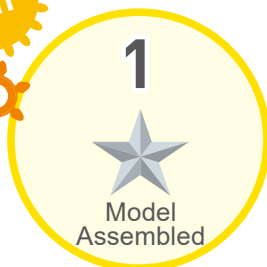

15 Monograph 3

Design a wind powered swinging sign with a light bulb by using principles or models you've discovered here.



11. Long-blade Windmill



12. Variable-speed Windmill

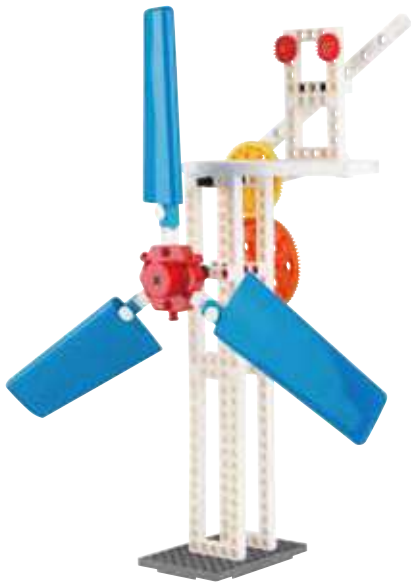

13. Wind-powered Scarecrow



14. Windmill Generator

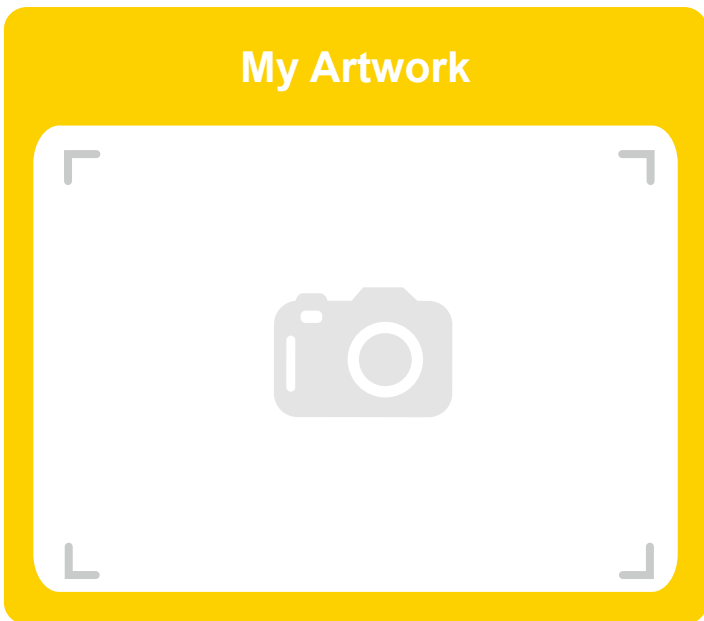
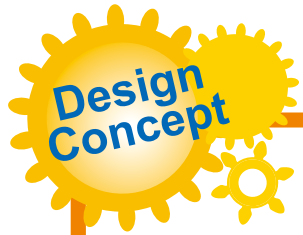

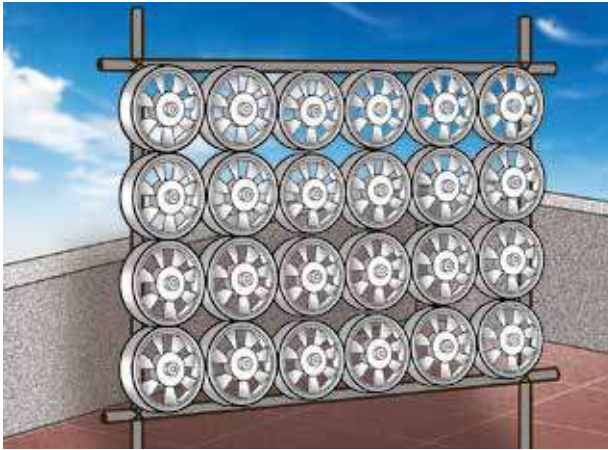

In order to encourage most cities to effectively use wind energy, researchers have developed a new micro wind turbine generator technology.

Micro wind turbines are specially designed with several lightweight plastic wind wheels. They have gears and windshields, and they are also equipped with a wind-seeking rudder. The windshield design decreases the

starting speed and increases the efficiency of power generation.

This kind of wind power generation system is able to work with a wind speed under a 2m/s. Although the amount of power generated is not high, it can serve as a small independent auxiliary power system that conserves energy.

Daily Application



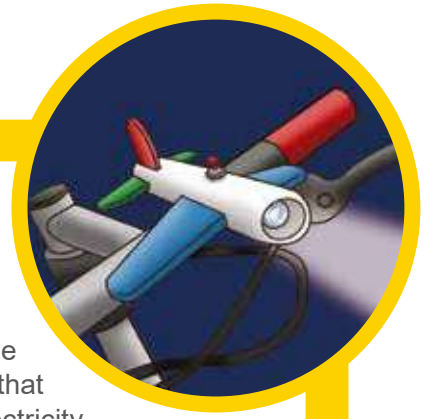

















A wind turbine has to overcome the static friction force in order to start rotating from a static state. This is called a start-up wind speed, i.e. there is a minimum wind speed required to start a wind turbine. The start-up speed of a common windmill is about 3m/s, but it is unable to generate electricity at a wind speed lower than 4m/s. To ensure that communities with a lower than average wind speed can generate electricity by wind, it is necessary to minimize the scale of the windmill to reduce the static friction force. Therefore, the so-called micro wind turbine can operate at half the start-up speed of a common generator, and can produce electricity even with a gentle breeze. However, its generated power level is relatively low. Because of small size, and portability feature, micro windmills on bicycles have already been invented.



Brainstorming

Where does strong wind normally appear?

Parts List

2	3	4	5	6	7	8	9	10	14	15	17
											
x1	x6	x6	x4	x1	x1	x3	x7	x1	x2	x2	x1
19	25	26	31	35	36	38	39	40	41		
											
x1	x1	x1	x1	x1	x1	x6	x1	x1	x1		

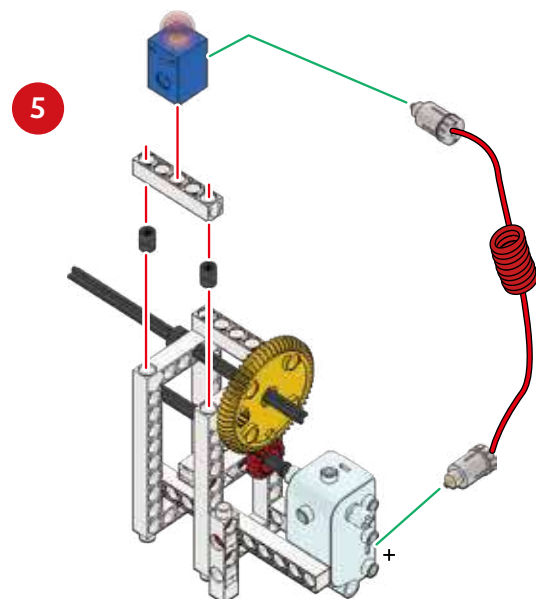
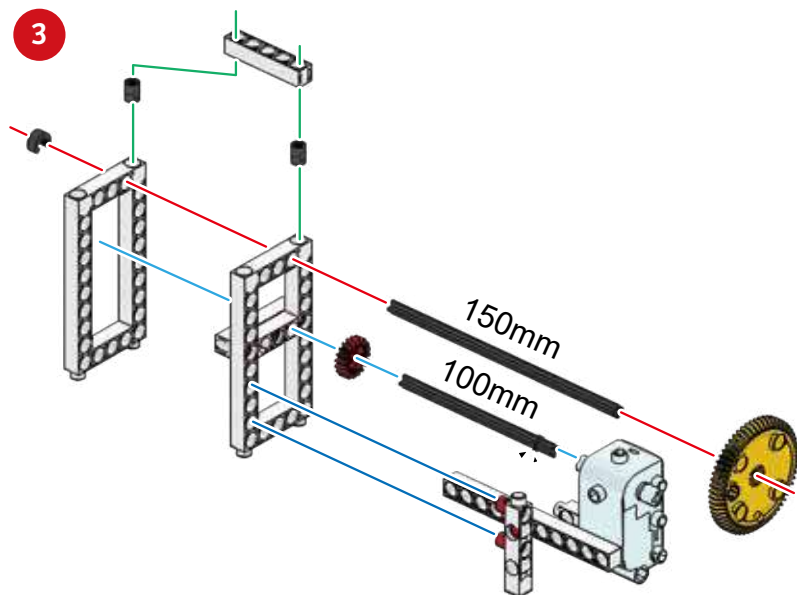
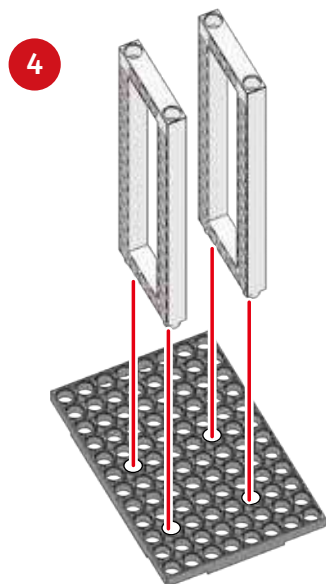
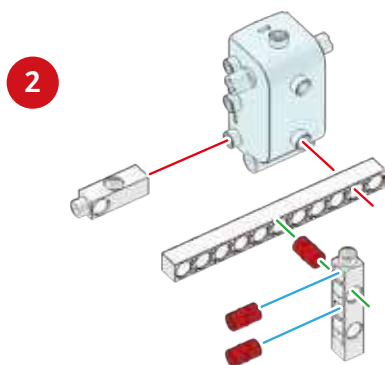
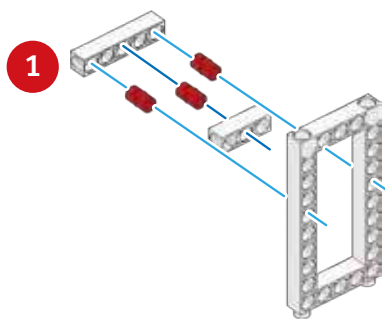

16

Micro Wind Turbine

6 x6

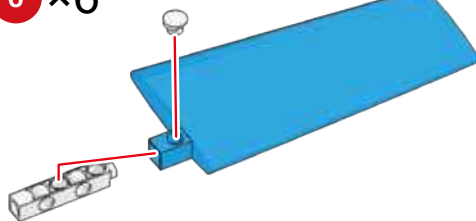

7

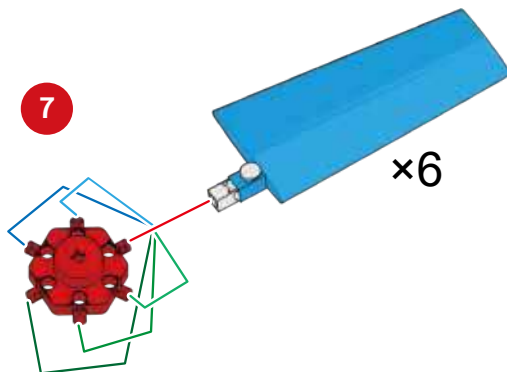

8

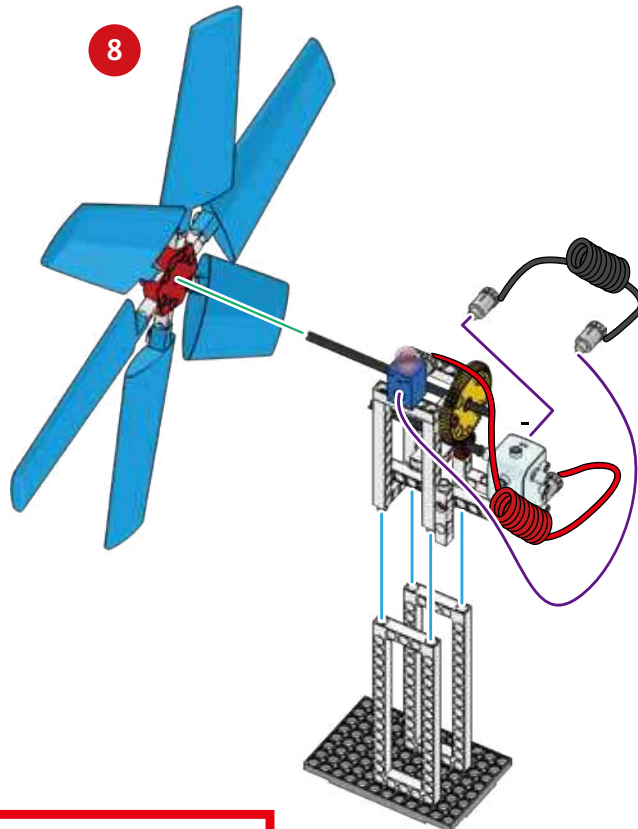

Done

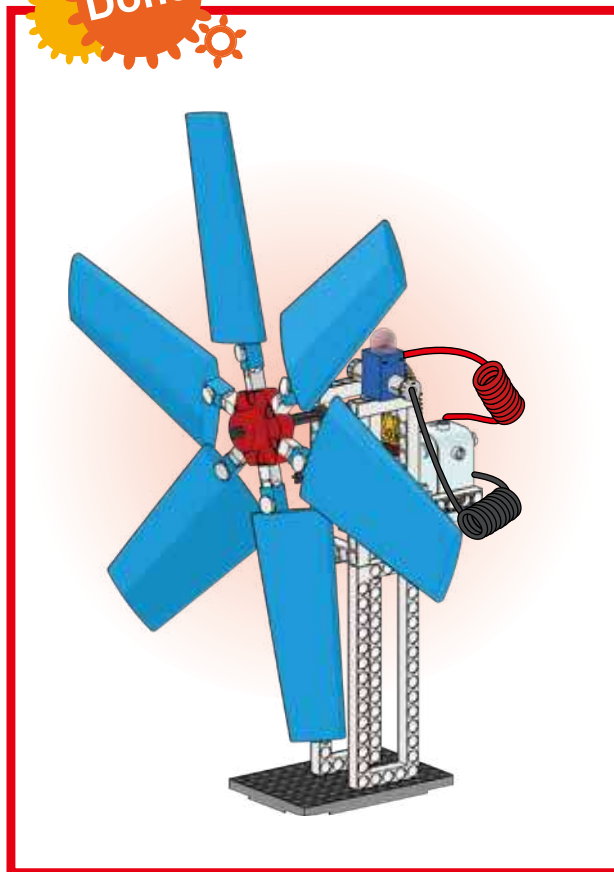

Model Operation
Video



Generate wind by using different methods and see which method can successfully drive a generator.

.....

.....

.....

.....

.....



If you want to mount a Micro Wind Turbine on a bicycle, where and how would you do it?

.....

.....

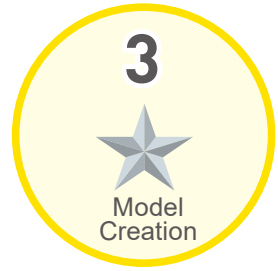
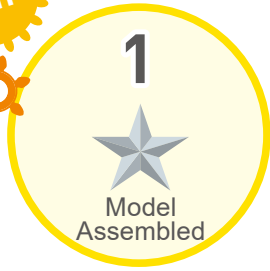

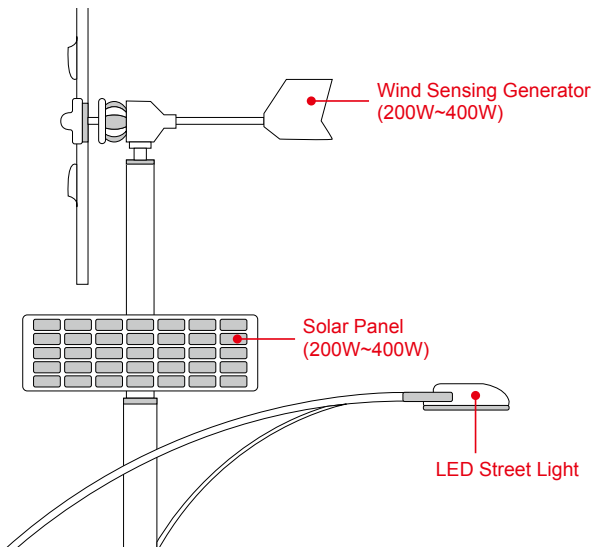

Grandpa took Gigi on a holiday to visit a chicken farm and help expand Gigi's knowledge about green energy. When she arrived on the farm, Gigi felt odd because of the strange street lights that she saw. There was a wind powered generator with a rudder at the point to steer the aerovane, and it had been installed on a pole for detecting the wind. There was also an integrated wind energy and solar panel for lighting.

Grandpa explained that although the individual transfer efficiency of both a wind powered generator and a solar panel were not high, the energy output can be increased if they are integrated. It is only when we exert some effort in environmental protection and energy conversation that the next generation can enjoy a better environment.

Daily Application

Horizontal wind turbine rotors convert wind energy to mechanical energy first, then turn it into electric energy. Due to engineering losses and transmission losses during conversion, output energy is always lower than input energy. If the wind wheel does not go windward, there will be less wind energy input. In order to capture the wind energy effectively, a wind-seeking device must be mounted. A large-scale wind powered generator can first detect wind direction and signal through a wind direction sensor and then control the direction of rotation. For small wind powered generators, a rudder will be mounted for the same reason. The larger surface has larger wind resistance, once the wind blows, it adjusts the direction of the generator automatically. When the turbine is windward, it increases the input of the energy, so even with low conversion efficiency, still ensures the wind power generator's best usage.



Brainstorming

How do you determine wind direction and strength in an area?

Parts List

2	3	4	5	6	8	9	10	13	14	15	17	18
x1	x1	x14	x6	x2	x5	x1	x1	x3	x3	x5	x1	x1
25	26	28	31	32	35	36	37	38	39	40	41	
x1	x1	x2	x1	x1	x1	x1	x3	x1	x1	x1	x1	

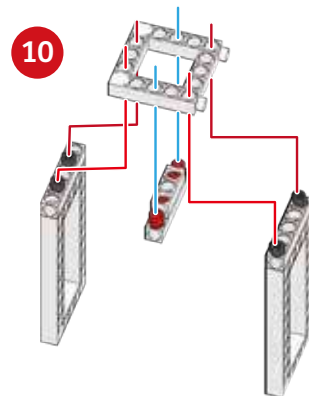
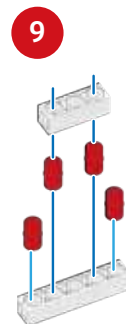
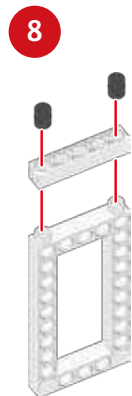
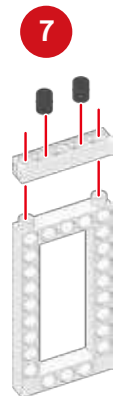
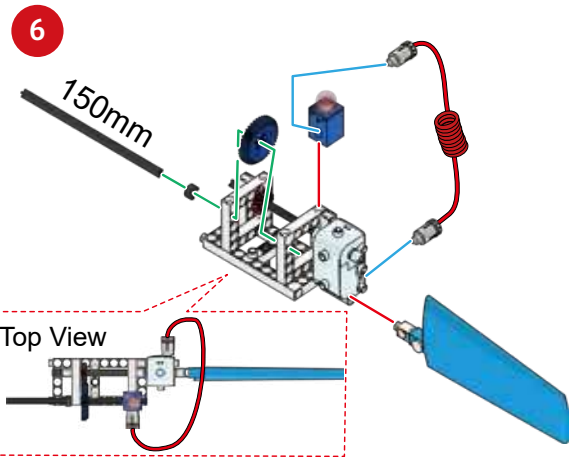
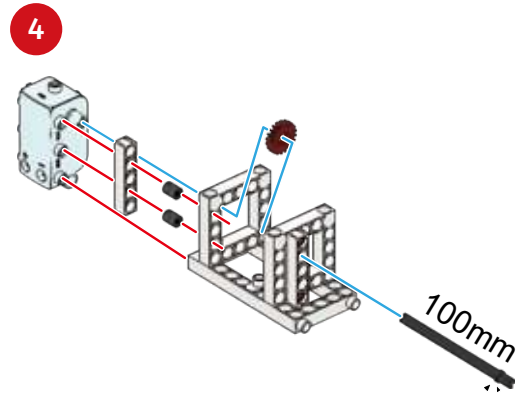
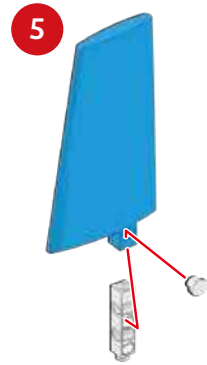
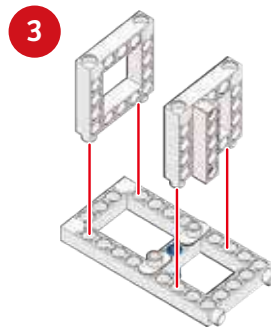
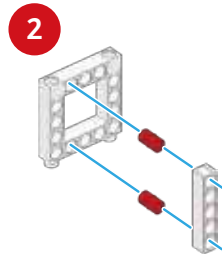
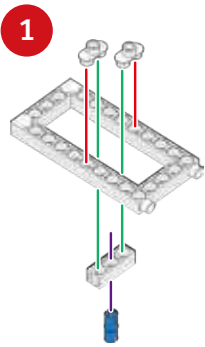

17

Wind Sensing Generator

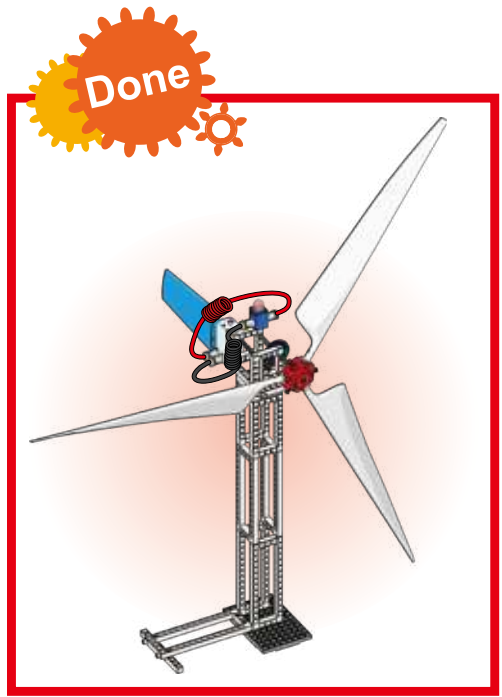
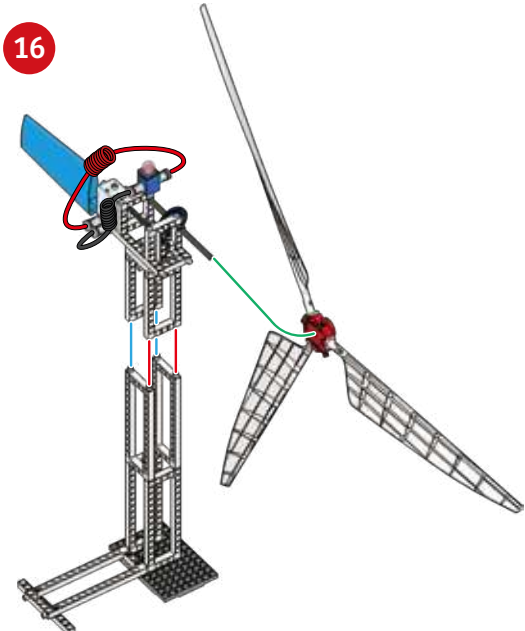
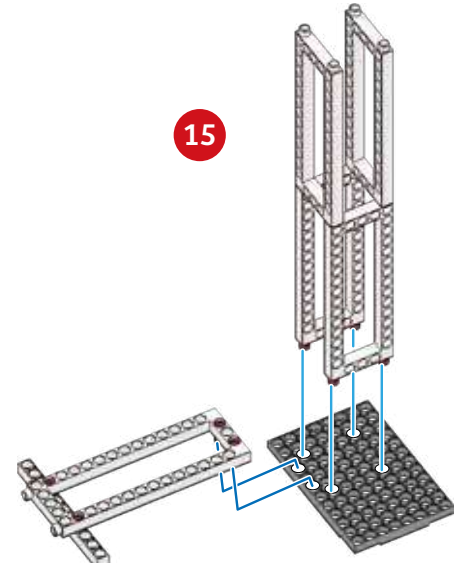
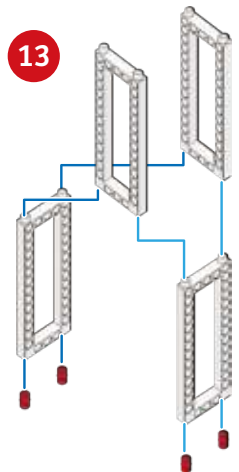
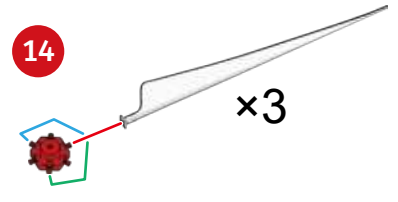
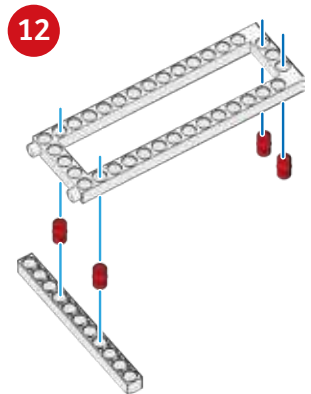
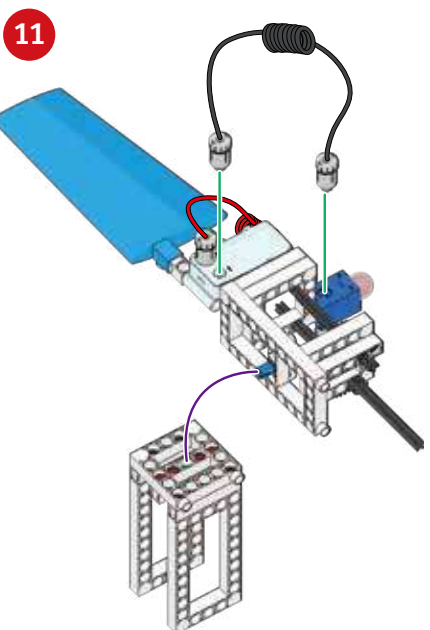

Model Operation Video



Make a model that is facing the electric fan at different angles and test whether it can change directions successfully in line with the wind's direction.

Blank writing area with horizontal dotted lines for notes.



How do you make a wind sensing function on a model more sensitive?

Blank writing area with horizontal dotted lines for notes.

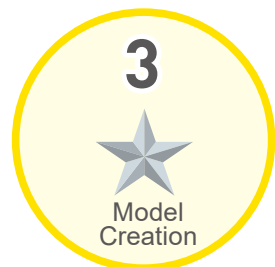
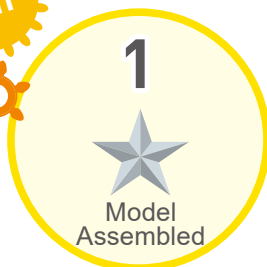



The world's first wind-powered electric vehicle charging station was installed successfully in Barcelona, Spain in 2012. It was an electric vehicle charging station that used wind for power generation and energy storage. It perfectly incorporated a pollution-free wind power generation and electric vehicle charging mechanism. It not only expanded the practical application a fresh new energy use, but helped popularize the electric vehicles.

Wind-powered electric vehicle charging stations consist of a 12-meter tower, in which a vertically aligned axis, wind power generator is installed. This transmits electricity to the charging station. A vertical axis wind powered generator only requires a small space for operation. Thus, it is small in terms of volume and is easily installed. It has the advantage of compactness, no limitations on wind direction or topography. Also it is easy to assemble, and generates low noise.

Daily Application

A wind powered generator is categorized according to its installation direction. In other words, a generator parallel to the ground is called a horizontal generator while a generator vertical to the earth called a vertical generator. Since the rotation in a vertical generator is perpendicular to the wind direction, and a vertical plate or a cambered bending plate is used as a turbine, there are several advantages which include receiving wind from any direction, a simple structural design and a small rotation range of blades. However, given the small turbine size and (heavy) weight, some may have to overcome a larger start-up friction, or at times, a motor to get started.



Brainstorming

Where does the wind blow from? What is the wind's direction?

Parts List

2 	3 	4 	5 	7 	8 	9 	10 	13 	15 	17 	18
x1	x6	x10	x10	x6	x3	x6	x6	x2	x2	x1	x1
19 	24 	26 	35 	36 	38 	39 	40 	41 			
x1	x1	x1	x1	x1	x1	x6	x1	x1	x1		

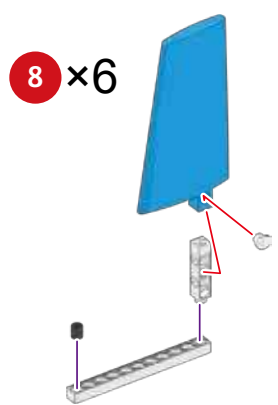
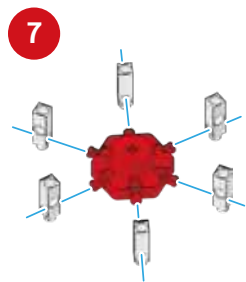
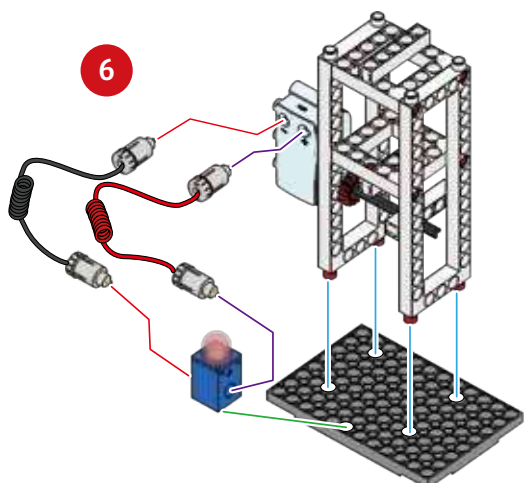
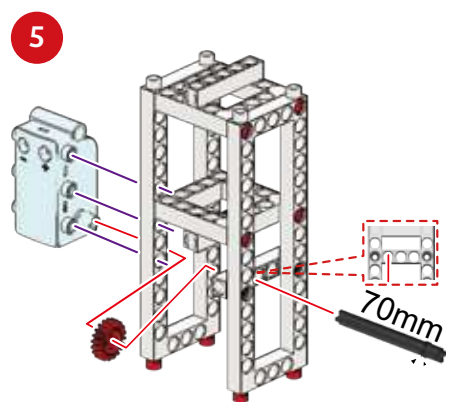
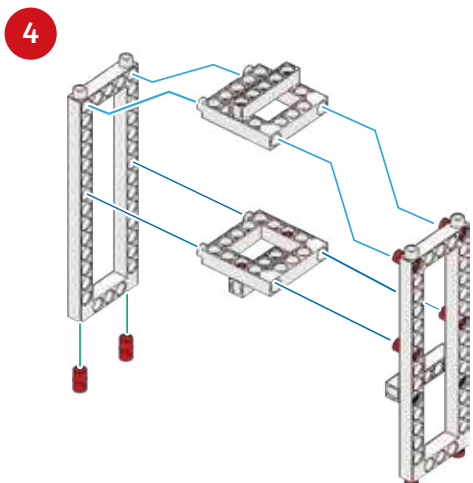
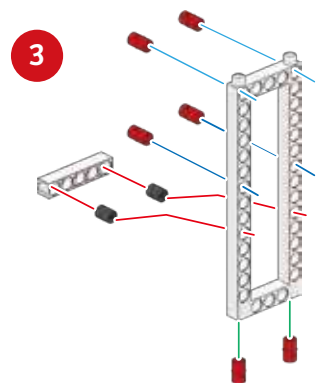
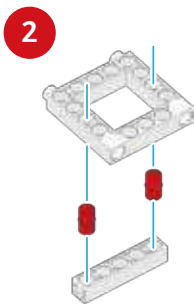
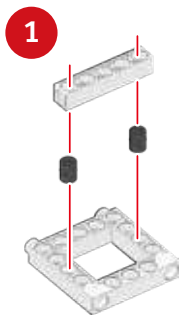

Vertical Wind Powered Generator

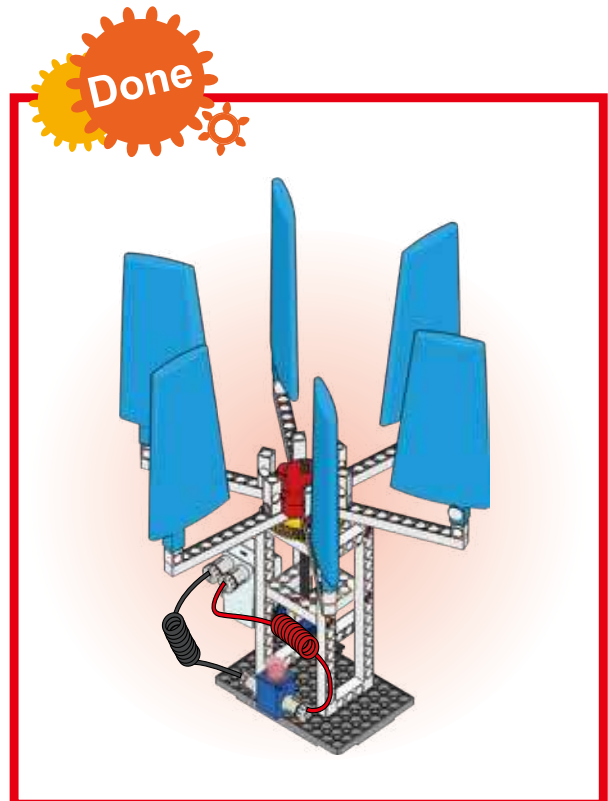
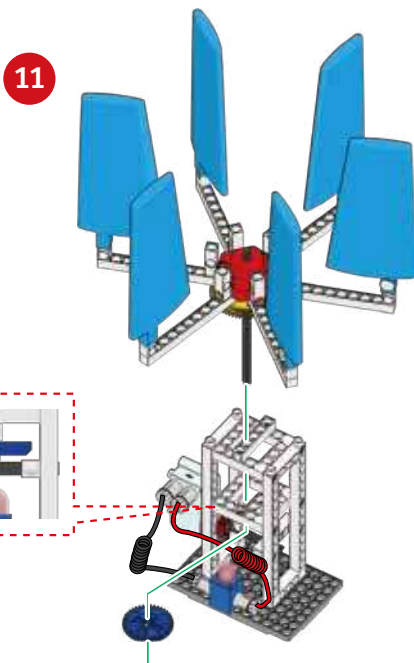
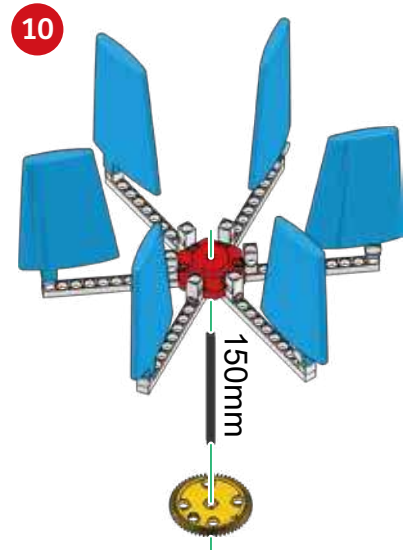
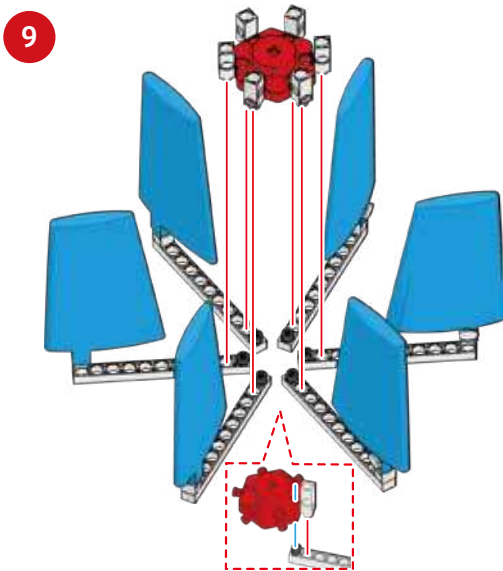

Model Operation
Video



Please use a device to blow wind from different angles and observe the difference in the model's action.

Blank writing area with horizontal dotted lines for notes.



How can you improve the generated power levels of a Vertical Wind Powered Generator?

Blank writing area with horizontal dotted lines for notes.

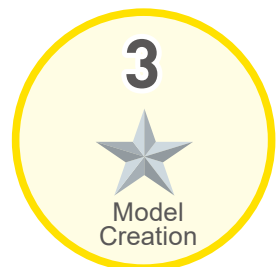
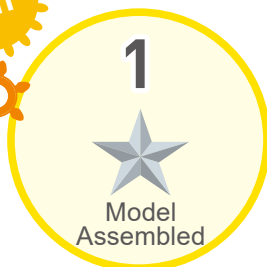



When Gogo let the electric fan blow the kite, he associated this action with power generation. Since a kite could be used to generate power, he assumed that an electric fan can also generate power. So he got curious and asked Grandpa.

Grandpa answered: “Generally, an electric fan powered by an alternating current has a horizontal rotating axle. Although it can be treated as a horizontal wind turbine, it cannot generate power. Because it uses an AC Induction Motor, its coils are fixed while its rotor and stator work through electro-magnetic induction. The iron core coated with aluminum generates the power by induction. Since the motor has no magnet, the coils are unable to cut the magnetic field for power generation.” In addition, the design of the fan blade greatly increases the wind resistance. It may result in lost balance and structural damage.

Note: What are rotor and stator? Most generators contain rotors and stators; rotors are parts that rotate, stators are parts that are fixed, both together create a magnetic field that leaves the mechanism running.

Daily Application

Generally, the blades of a general fan are twisted at an angle to “push” the air. Thus a lower pressure may form behind the fan during its rotation. Some people can feel a suction-like force working behind the fan. When the blades spin, the bevel angle of the blades produce friction with the air, which is then pushed forward. The pushed air also exerts pressure on the blades, because, according to Newton’s principle of action and reaction as pushed air is released from the electric fan another force friction, pushes the blades back.

Brainstorming

What kinds of electric fans have you seen?

Parts List

2	3	4	5	8	9	13	14	15	17	18	24
x1	x3	x4	x2	x1	x3	x3	x3	x2	x1	x1	x1
26	35	38	39	40	41	42					
x1	x1	x3	x1	x1	x1	x1					

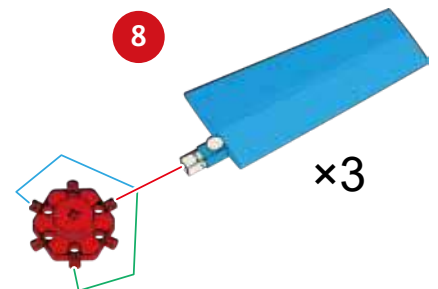
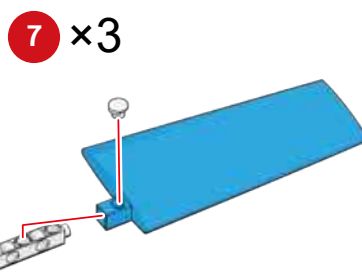
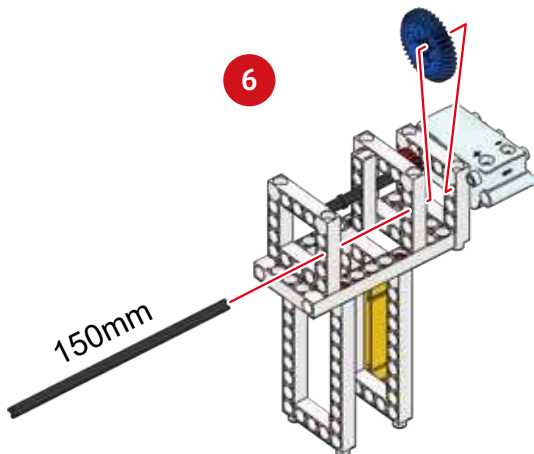
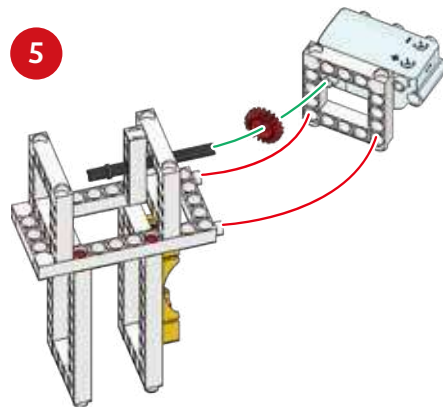
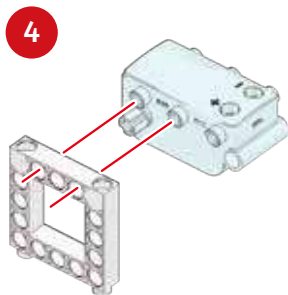
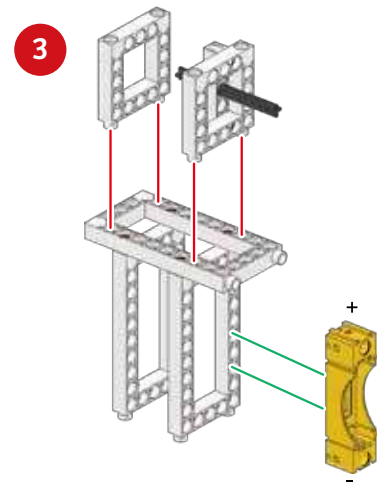
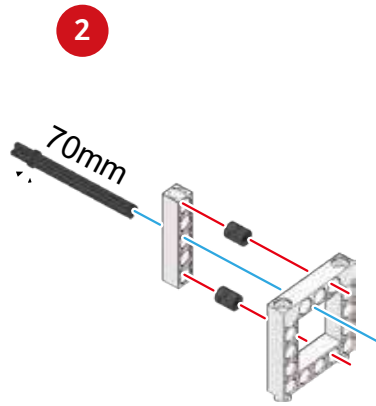
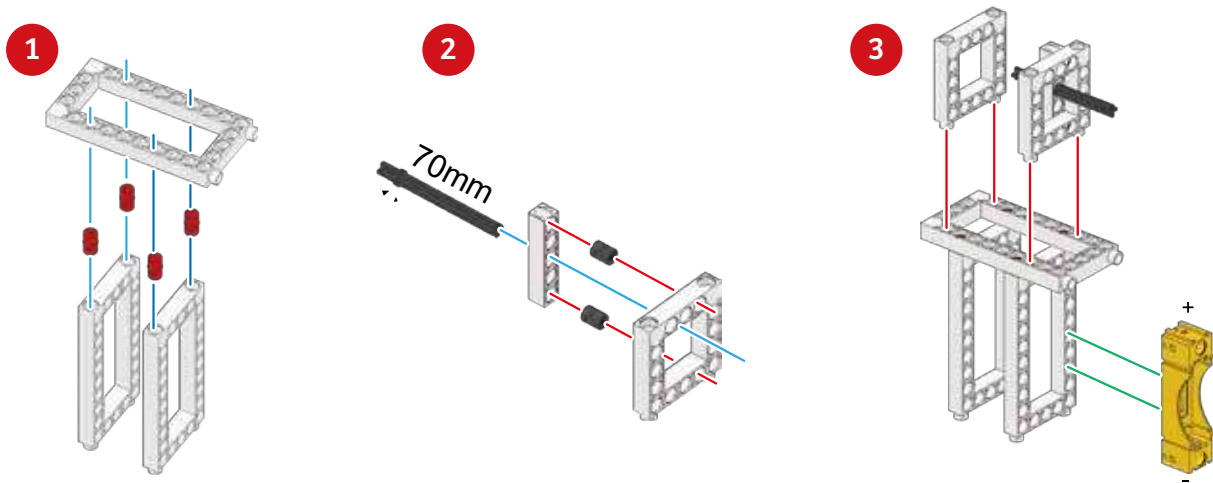

19

Electric Fan

9

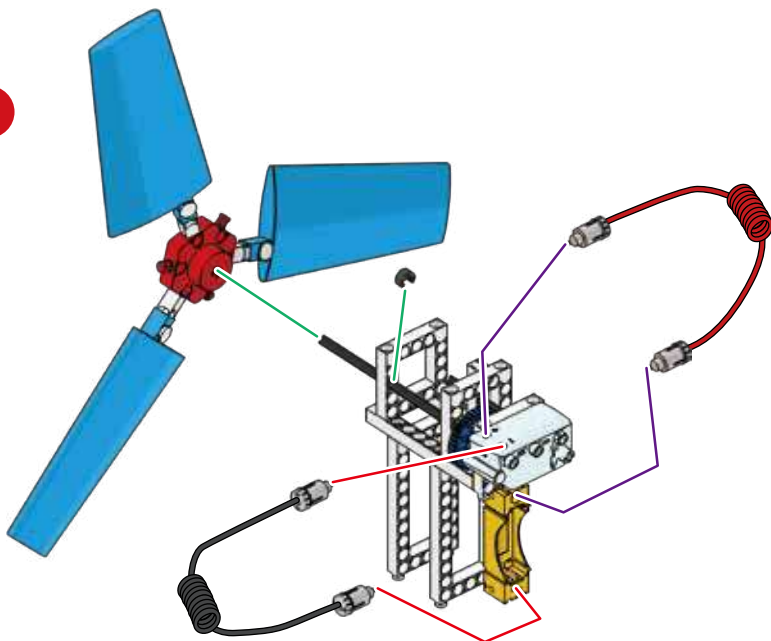

10

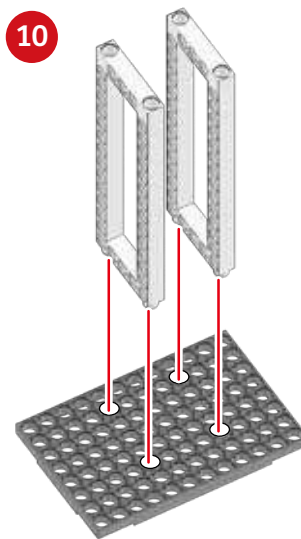

11

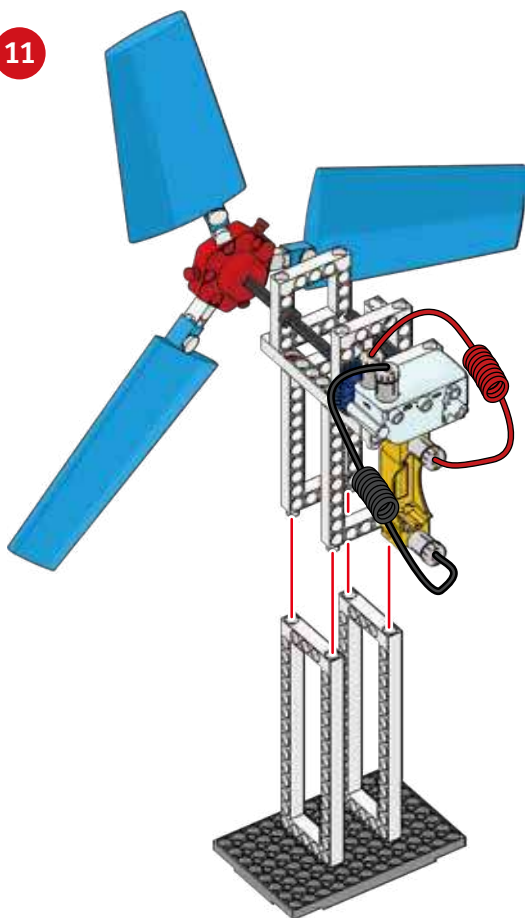

Done

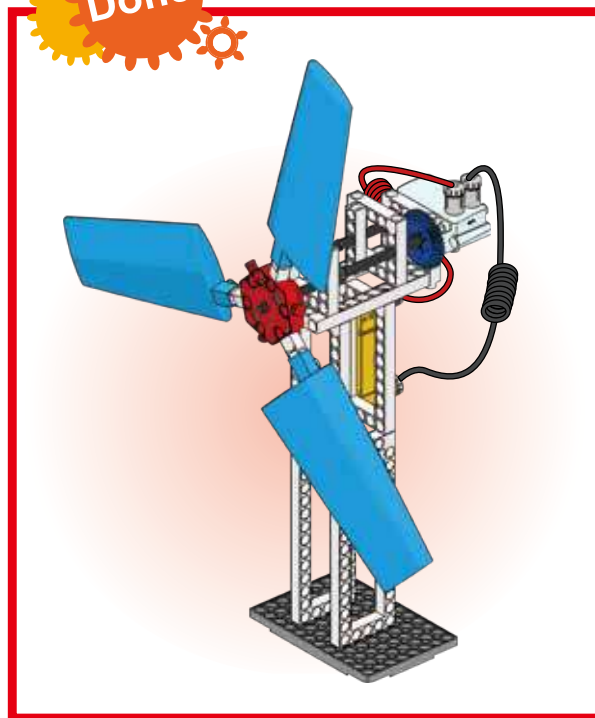

Model Operation
Video



Now, to allow the fan to operate at different speeds, add a gearing system to your model.

Blank writing area with horizontal dotted lines for notes.



Change the appearance of your Electric Fan and think of some places that you can use it.

Blank writing area with horizontal dotted lines for notes.

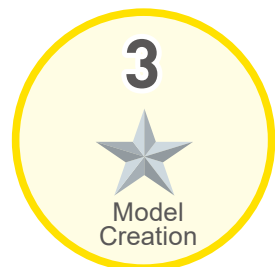
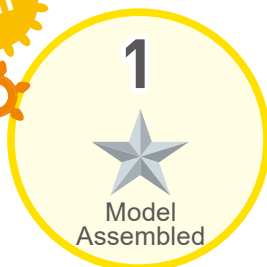

Design a wind-seeking generator with shift gears using a principle or model you've learnt about here.

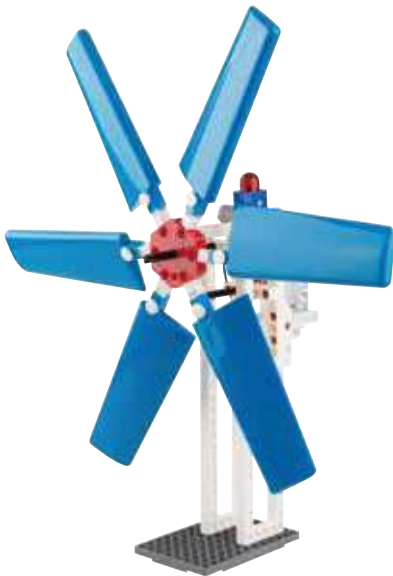

16. Micro Wind Turbine



17. Wind Sensing Generator



18. Vertical Wind Powered Generator



19. Electric Fan

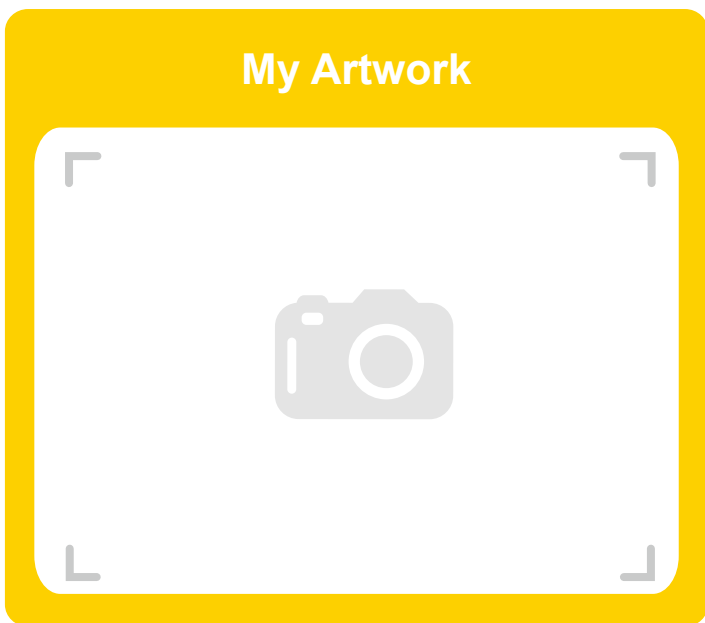
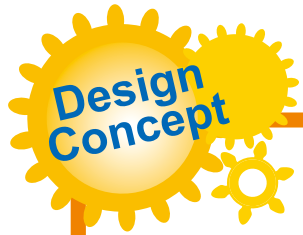

- 1
★
Model Design
- 2
★
Model Creation
- 3
★
Winner!

Appendix - Paper Card

L6 Single-sail Sail Car

Paper card- Sail 1
(Please copy for use.)



Gently fold along the top of the sail, then button the paper card using the hole and fixer as shown.

There should be a gentle curve at the top and bottom of the sail.

L6 Windsurfing Sail Car

Paper card- Sail 2
(Please copy for use.)



Carefully fold in the card in half, and fold the outer flaps inward to the center line. When you have pressed both sides into the center, paste them with tape or paper glue so they do not move.

Next, make a small hole and use it to button the paper card to the model.



MADE IN TAIWAN

GENIUS TOY TAIWAN CO., LTD.
www.gigotoys.com

© 2021 Genius Toy Taiwan Co., Ltd. ALL RIGHTS RESERVED **R21#1239RR**